

Internal Geared Hub 11-speed (Di2)



User's manuals in other languages are available at :
<http://si.shimano.com>

IMPORTANT NOTICE

- Contact the place of purchase or a bicycle dealer for information on installation and adjustment of the products which are not found in the user's manual. A dealer's manual for professional and experienced bicycle mechanics is available on our website (<http://si.shimano.com>).
- Do not disassemble or alter this product.

For safety, be sure to read this user's manual thoroughly before use, and follow them for correct use.

Important Safety Information

Guidelines that require replacement, contact the place of purchase or a bicycle dealer.

WARNING

- It is important to completely understand the operation of your bicycle's brake system. Improper use of your bicycle's brake system may result in a loss of control or a fall, which could lead to severe injury. Because each bicycle may handle differently, be sure to learn the proper braking technique (including brake lever pressure and bicycle control characteristics) and operation of your bicycle. This can be done by consulting your professional bicycle dealer and the bicycle's owners manual, and by practicing your riding and braking technique.
- Check that the wheels are fastened securely before riding the bicycle. If the wheels are loose in any way, they may come off the bicycle and serious injury may result.
- After reading the user's manual carefully, keep it in a safe place for later reference.

Note

- You can shift gears while pedaling, but on rare occasions the pawls and ratchet inside the hub may produce some noise afterwards as part of normal gear shifting operation.
- The 11-speed hub has a built-in mechanism to support shifting. When this support mechanism operates during shifting, noise or vibration may occur. The shifting feel may also change depending on the gear position at the time of shifting. Noise may also be generated if the crank arms are turned backward or if the bicycle is pushed backward when the gear position is 7 – 11. These occurrences are a normal result of the structure of the internal gear shifting mechanism, and are not a sign of a malfunction.
- The bolt on the hub shell is the bolt used when changing the oil. Never loosen this bolt except to change the oil. Doing so may cause oil to leak out, resulting in splashing.
- In order to maintain proper performance, it is recommended that you contact the place of purchase or a bicycle dealer to carry out maintenance such as internal oil replacement after riding 1,000 km from the start of use and after that, about once every two years (or once about every 5,000 km if the bicycle is used very frequently).
- The internal hub is not completely waterproof. Avoid using the hub in places where water might get inside it and do not use high-pressure water to clean the hub, otherwise the internal mechanism may rust.
- You should periodically wash the chainrings in a neutral detergent. In addition, cleaning the chain with neutral detergent and lubricating it can be an effective way of extending the useful life of the chainrings and the chain.
- If chain skipping has started occurring, replace the gears and the chain at a dealer or an agency.
- Products are not guaranteed against natural wear and deterioration from normal use and aging.
- For maximum performance we highly recommend Shimano lubricants and maintenance products.

Regular inspections before riding the bicycle

Before riding the bicycle, check the following items. If any problems are found with the following items, contact the place of purchase or a bicycle dealer.

- Is gear shifting carried out smoothly?
- Is there any noticeable damage to the electric wires?
- Do any abnormal noises occur during operation?

Names of parts

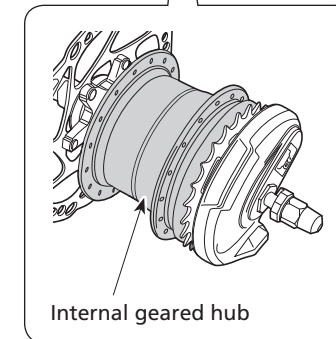

SHIMANO

SHIMANO AMERICAN CORPORATION
One Holland, Irvine, California 92618, U.S.A. Phone: +1-949-951-5003

SHIMANO EUROPE B.V.
Industrieweg 24, 8071 CT Nunspeet, The Netherlands Phone: +31-341-272222

SHIMANO INC.
3-77 Oimatsu-cho, Sakai-ku, Sakai-shi, Osaka 590-8577, Japan

Please note: specifications are subject to change for improvement without notice. (English)
© May 2012 by Shimano Inc. HTR SZK