

## Dealer's manual

# SHIMANO STEPS

## E6000 Series

SC-E6000  
SC-E6010  
SC-S705  
SW-E6000  
SW-S705  
FC-E6000  
SM-CRE60  
DU-E6000  
DU-E6001  
DU-E6010  
DU-E6050  
SM-DUE01  
BT-E6000  
BT-E6001  
BT-E6010  
BT-E8010  
BT-E8020  
BM-E6000  
BM-E6010  
SM-BME60  
SM-BME61  
BM-E8010  
BM-E8020  
SM-BCE60  
EC-E6000  
TL-FC38  
TL-DUE60

# CONTENTS

<b>IMPORTANT NOTICE.....</b>	<b>4</b>
<b>TO ENSURE SAFETY.....</b>	<b>5</b>
<b>INSTALLATION .....</b>	<b>9</b>
Names of parts .....	11
Product specifications .....	12
Installing the cycle computer .....	13
Installing and removing the cycle computer .....	14
Adjusting the angle of the cycle computer .....	14
Using the cable band to attach the assist switch to the handlebar.....	15
Installing the assist switch .....	15
Installing the battery mount .....	17
Installing the battery .....	31
Removing the battery .....	33
Installing the speed sensor .....	36
Mounting the magnet .....	37
<b>INSTALLING AND WIRING THE DRIVE UNIT .....</b>	<b>39</b>
Installing the drive unit .....	39
Drive unit wiring diagram .....	39
Connecting the power cord.....	40
Installing the ferrite core (DU-E6001/E6010/E6050).....	41
Connecting the electric wire .....	42
Connecting the assist switch and drive unit to the cycle computer.....	42
Connecting the speed sensor to the drive unit .....	43
Connecting the light adapter to the drive unit .....	43
Installing the ferrite core (MU-S705) .....	45
Installing the crank and front chainring.....	46
Measuring and adjusting the chain tension.....	48

<b>CHARGING THE BATTERY.....</b>	<b>51</b>
Introduction.....	51
Proper use of the battery .....	51
Charging procedures.....	51
About the charger LED lamp.....	54
About the battery LED lamps.....	54
Turning the power ON / OFF .....	56
 <b>CYCLE COMPUTER DISPLAY AND SETTING.....</b>	 <b>58</b>
Names and functions of the parts of the assist switch .....	58
Basic screen display of the cycle computer.....	59
Changing the settings.....	67
Error messages on the cycle computer .....	80
 <b>CONNECTION AND COMMUNICATION WITH PC.....</b>	 <b>84</b>
Drive unit setting backup function for the cycle computer .....	84
Settings customizable in E-TUBE PROJECT .....	85
Connecting to the PC.....	86
 <b>MAINTENANCE.....</b>	 <b>89</b>
Replacing the front chainring .....	89

## IMPORTANT NOTICE

- **This dealer's manual is intended primarily for use by professional bicycle mechanics.**  
Users who are not professionally trained for bicycle assembly should not attempt to install the components themselves using the dealer's manuals. If any part of the information on the manual is unclear to you, do not proceed with the installation. Instead, contact your place of purchase or a local bicycle dealer for their assistance.
- Make sure to read all instruction manuals included with the product.
- Do not disassemble or modify the product other than as stated in the information contained in this dealer's manual.
- All dealer's manuals and instruction manuals can be viewed on-line on our website (<http://si.shimano.com>).
- Please observe the appropriate rules and regulations of the country, state or region in which you conduct your business as a dealer.

**For safety, be sure to read this dealer's manual thoroughly before use, and follow it for correct use.**

The following instructions must be observed at all times in order to prevent personal injury and physical damage to equipment and surroundings. The instructions are classified according to the degree of danger or damage which may occur if the product is used incorrectly.

 **DANGER**

Failure to follow the instructions will result in death or serious injury.

 **WARNING**

Failure to follow the instructions could result in death or serious injury.

 **CAUTION**

Failure to follow the instructions could cause personal injury or physical damage to equipment and surroundings.

## TO ENSURE SAFETY

### DANGER

Be sure to also inform users of the following:

#### ■ Handling the battery

- Do not deform, modify, disassemble or apply solder directly to the battery. Doing so may cause leakage, overheating, bursting, or ignition of the battery.
- Do not leave the battery near sources of heat such as heaters. Do not heat the battery or throw it into a fire. Doing so may cause bursting or ignition of the battery.
- Do not subject the battery to strong shocks or throw it. If this is not observed, overheating, bursting, or fire may occur.
- Do not place the battery into fresh water or sea water, and do not allow the battery terminals to get wet. Doing so may cause overheating, bursting, or ignition of the battery.
- Use the Shimano specified charger and observe the specified charging conditions when charging the specified battery. Not doing so may cause overheating, bursting, or ignition of the battery.

### WARNING

#### • Be sure to follow the instructions provided in the manuals when installing the product.

It is recommended that you use only genuine Shimano parts. If parts such as bolts and nuts become loose or damaged, the bicycle may suddenly fall over, which may cause serious injury. In addition, if adjustments are not carried out correctly, problems may occur, and the bicycle may suddenly fall over, which may cause serious injury.

-  Be sure to wear safety glasses or goggles to protect your eyes while performing maintenance tasks such as replacing parts.
- For information on products not explained in this manual, refer to the manuals provided with each product.
- After reading the dealer's manual thoroughly, keep it in a safe place for later reference.

Be sure to also inform users of the following:

- Be careful not to let yourself be distracted by the cycle computer display while riding the bicycle. Otherwise, you may fall off the bicycle.
- Before riding, check that the wheels are secured. Otherwise, you may fall off the bicycle and be seriously injured.
- Be sufficiently familiar with how to start the power assisted bicycle before riding on busy streets. Otherwise, you may start the bicycle abruptly and have an accident.
- Make sure that the light is on during night riding.
- Do not disassemble the product. Disassembling it may cause injury to persons.
- When charging the battery while it is installed on the bicycle, do not move the bicycle. The battery charger's power plug may not be completely inserted into the outlet, which may lead to fire.

**■ Lithium Ion Battery**

- If any liquid leaking from the battery gets into your eyes, immediately wash the affected area thoroughly with clean water such as tap water without rubbing your eyes, and seek medical advice immediately. If this is not done, the battery liquid may damage your eyes.
- Do not recharge the battery in very humid places or the outdoors. If this is not observed, electric shocks may result.
- Do not insert or remove the plug while it is wet. If this is not observed, electric shocks may result. If there is water leaking out of the plug, dry it thoroughly before inserting it.
- If the battery does not become fully charged after 6 hours of charging, immediately unplug the battery from the outlet and contact the place of purchase. Failure to do so may cause overheating, bursting, or ignition of the battery.
- Do not use the battery if it has any noticeable scratches or other external damage. Doing so may cause bursting, overheating or problems with operation.
- The operating temperature ranges for the battery are given below. Do not use the battery in temperatures outside these ranges. If the battery is used or stored in temperatures outside these ranges, fire, injury or problems with operation may occur.
  1. During discharge: -10 °C - 50 °C
  2. During charging: 0 °C - 40 °C

**■ Items related to installation to and maintenance of the bicycle**

- Be sure to remove the battery and charger before wiring or attaching parts to the bicycle. Otherwise, an electric shock may result.
- Be sure to follow the instructions provided in the manuals when installing the product. It is recommended that you use only genuine Shimano parts. If bolts and nuts become loose or the product is damaged, the bicycle may suddenly fall over, resulting in a serious injury.
- Maintenance interval depends on the usage and riding circumstances. Clean regularly the chain with an appropriate chain cleaner. Never use alkali based or acid based solvents such as rust cleaners. If those solvent be used chain might break and cause serious injury.

** CAUTION****Be sure to also inform users of the following:**

- Observe the instructions in the user's manual for the bicycle, in order to ride safely.
- Periodically check the battery charger and adapter, particularly the cord, plug, and case, for any damage. If the charger or adapter is broken, do not use it until it has been repaired.
- Use the product under the direction of a safety supervisor or the directions for use. Do not allow physically, sensory, or mentally impaired persons, inexperienced persons, or persons with no required knowledge including children to use this instrument.
- Do not allow children to play near the product.
- If any malfunction or trouble occurs, consult the dealer nearest you.
- Never modify the system. This may cause a malfunction in the system.

**■ Lithium Ion Battery**

- Do not leave the battery in a place exposed to direct sunlight, inside a vehicle on a hot day, or other hot places. This may result in battery leakage.
- If any leaked fluid gets on your skin or clothes, wash it off immediately with clean water. Otherwise, the leaked fluid may damage your skin.
- Store the battery in a safe place out of the reach of infants and pets.

## NOTE

**Be sure to also inform users of the following:**

- Be sure to attach dummy plugs to any unused ports.
- For installation and adjustment of the product, consult a dealer.
- The units are designed to be fully waterproof to withstand wet weather riding conditions. However, do not deliberately place them into water.
- Do not clean the bicycle with a high-pressure washer. If water gets into any of the components, operating problems or rusting may result.
- Handle the components carefully, and avoid subjecting them to any strong shocks.
- Do not place the bicycle upside down. Doing so may damage the cycle computer or shift switch.
- Although the bicycle still functions as a normal bicycle even when the battery is removed, the light does not turn on if it is connected to the electric power system. Be aware that using the bicycle under these conditions will be considered non-observance of the road traffic laws in Germany.
- When carrying the bicycle in a car, remove the battery from the bicycle and place it on a stable surface in the car.
- Before connecting the battery, make sure that there is no water collecting in the connector where the battery will be connected.
- When charging the battery while it is mounted on the bicycle, be careful of the following:
  - When charging, make sure there is no water on the charging port or the charger plug.
  - Check that the battery mount is locked before charging.
  - Do not remove the battery from the battery mount while charging.
  - Do not ride the bicycle with the battery charger mounted on.
  - Close the charging port cap when not charging.
  - Stabilize the bicycle to ensure that it does not collapse during charging.
- The use of a genuine Shimano battery is recommended. If using a battery from another manufacturer, make sure to carefully read the instruction manual for the battery before use.
- It may not be possible to turn the power on from the cycle computer (SC-E6010) when the cycle computer is used or left for long periods of time at low temperatures. Press the battery's power button to turn the power on. If the power still does not turn on, contact the place of purchase.
- Some of the important information in this dealer's manual can also be found on the device labels.
- The number found on the battery key is necessary when purchasing spare keys. Store it carefully.
- Use a damp cloth, with the water well wrung out, when cleaning the battery and plastic cover.
- If you have any questions about the use and maintenance of the product, consult the dealer where you made the purchase.
- Contact the place of purchase for updates of the component software. The most up-to-date information is available on the Shimano website. For details, refer to the "Connection and communication with the PC" section.
- Products are not guaranteed against natural wear and deterioration from normal use and aging.
- For maximum performance we highly recommend Shimano lubricants and maintenance products.

**■ Lithium Ion Battery****Disposal information for countries outside the European Union**

This symbol is only valid within the European Union.  
Follow local regulations when disposing of used batteries. If you are not sure, consult the place of purchase or a bicycle dealer.

**■ Items related to installation to and maintenance of the bicycle**

- Do not use thinner or other solvents to clean any of the components. Such substances may damage the surfaces.
- You should periodically wash the chainrings in a neutral detergent. In addition, cleaning the chain with neutral detergent and lubricating it can be an effective way of extending the useful life of the chainrings and the chain.
- The proper assistance cannot be achieved unless the proper settings have been made (installation of the crank in the proper position, proper adjustment of the chain tension, etc.). Be particularly careful with these settings for the DU-E6010 which is compatible with coaster brakes.

The actual product may differ from the illustration because this manual is intended chiefly to explain the procedures for using the product.

















# INSTALLATION









# INSTALLATION

## List of tools to be used

The following tools are required to assemble the product.

Component	Where to use		Tool
Cycle computers	Handlebar fixing bolt		Screwdriver [#2]
	Angle adjustment screw		Screwdriver [#2]
Assist switch	Fixing bolt		Screwdriver [#2]
Battery Mount (SM-BME61)	Key unit Mount lower case		3mm hexagon wrench
	Key unit cover Mount upper case		Screwdriver [#1]
Battery mount (BM-E8010)	Mount lower case	 	3mm hexagon wrench / 8mm spanner
	Key unit		3mm hexagon wrench
	Key unit cover		2.5mm hexagon wrench
	Mount upper case		2.5mm hexagon wrench
Battery mount (BM-E8020)	Mount lower case		5mm hexagon wrench
	Mount upper case		Screwdriver [#2]
	Key cylinder		2mm hexagon wrench
	Key unit		5mm hexagon wrench
	Key unit cover		Screwdriver [#2]
Speed sensor	Speed sensor fixing bolt		4mm hexagon wrench

Component	Where to use	Tool	
Magnet unit	Mounting screw		Screwdriver [#2]
Electric wire	Connector		TL-EW02
Light adapter	Unit fixing screw		Screwdriver [#2]
Drive Unit	Frame installation bolt		M8 bolt and nut-compatible*
	Cover fixing bolt (M3)		Screwdriver [#2]
Front chainring	Lock ring		TL-FC32 / 36+TL-FC38
Crank arm	Crank installation bolt		14 mm socket wrench
Chain	Chain		TL-DUE60

\* For information on compatible tools, contact a manufacturer of completed bicycles.

■ Names of parts

In the case of mechanical gear shifting system

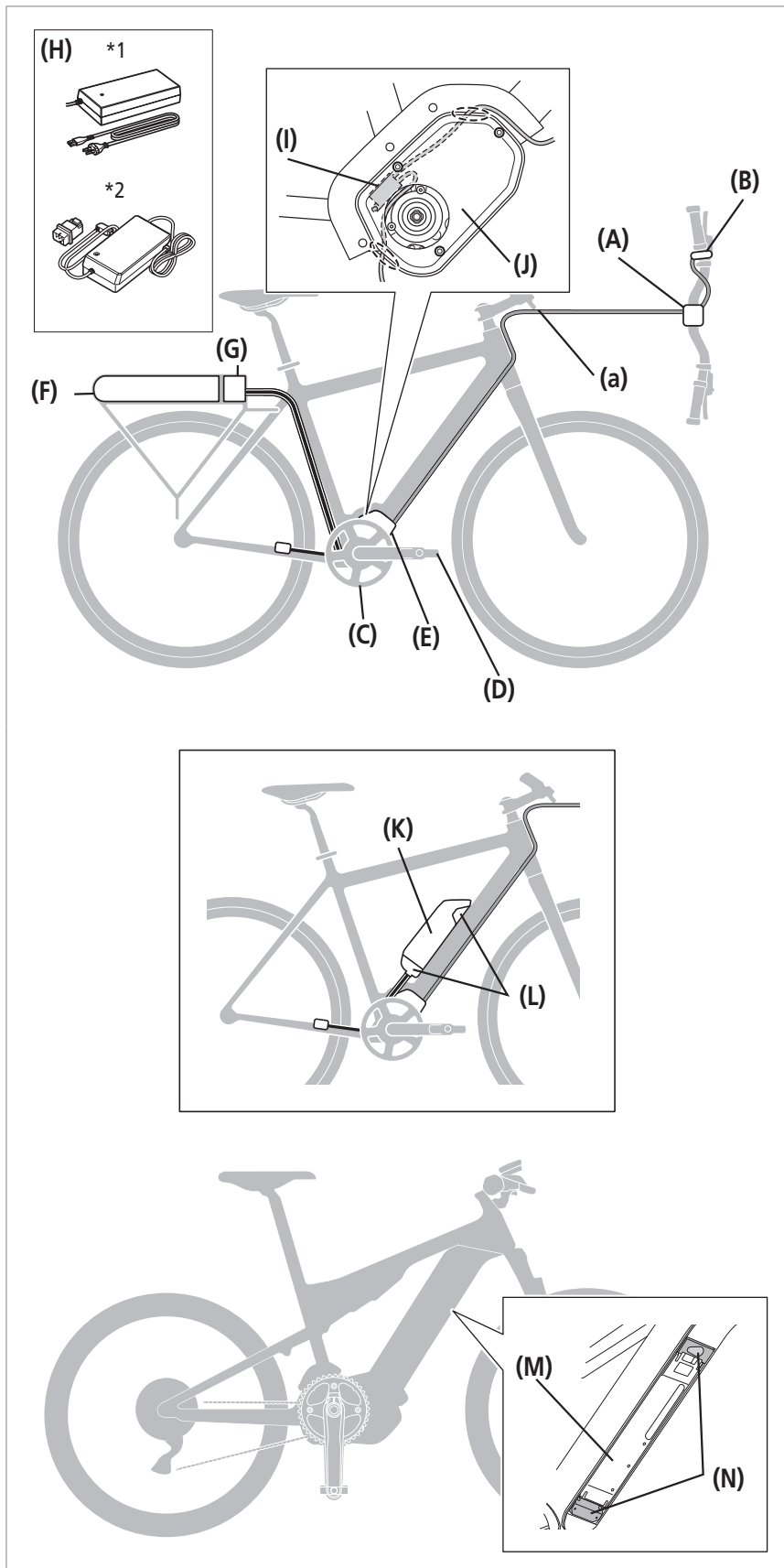

<b>(A)</b> Cycle computer	SC-E6000/ SC-E6010
<b>(B)</b> Assist switch	SW-E6000
<b>(C)</b> Front chainring	SM-CRE60
<b>(D)</b> Crank arm	FC-E6000
<b>(E)</b> Drive unit /Speed sensor	DU-E6000 DU-E6001 DU-E6010 DU-E6050
<b>(F)</b> Battery (external type)	BT-E6000 BT-E6001*3
<b>(G)</b> Battery Mount (external type)	SM-BME60 BM-E6000
<b>(H)</b> Battery charger	*1: SM-BCE60 +SM-BCC1 *2: EC-E6000
<b>(I)</b> Light adapter	SM-DUE01
<b>(J)</b> Drive unit cover	SM-DUE60
<b>(K)</b> Battery (external type)	BT-E6010 BT-E8010*3
<b>(L)</b> Battery Mount (external type)	SM-BME61 BM-E6010 BM-E8010
<b>(M)</b> Battery (built-in type)	BT-E8020*3
<b>(N)</b> Battery mount (external type)	BM-E8020

\* 3 If the firmware version of the drive unit is 3.2.6 or lower, the battery may not operate properly. Update the firmware version via E-TUBE PROJECT.

≡ Wire harness

— E-TUBE



 **TECH TIPS**

- The drive specification may be of the belt type. In this case, the front chainring, rear sprocket and belt are supplied by the belt's manufacturer. Also, for details concerning assembly and adjustment, refer to the technical information provided by the belt manufacturer.
- **Maximum cable length (EW-SD50)**  
(a) ≤ 1600 mm

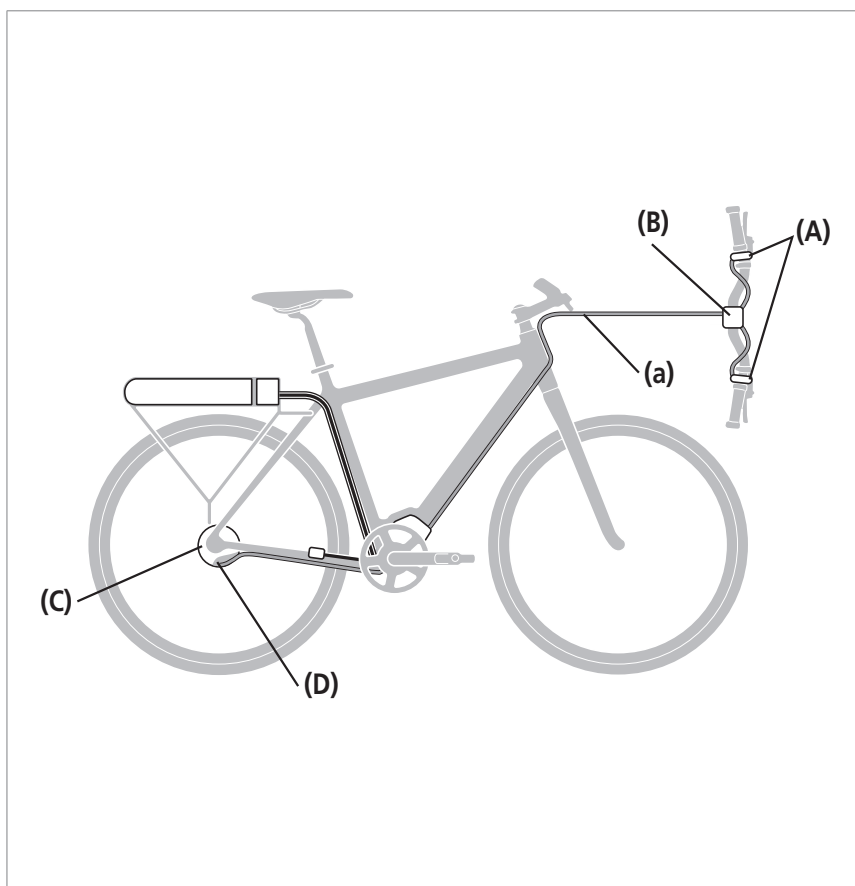
**In the case of electronic internal geared hub system**



<b>(A)</b> Assist/Shift switch	SW-E6000 SW-S705
<b>(B)</b> Cycle computer	SC-E6000 SC-E6010
<b>(C)</b> Motor unit	MU-S705
<b>(D)</b> Internal geared hub	SG-C6060 SG-S705 SG-S505

 Wire harness  
 E-TUBE

**TECH TIPS**

- The drive specification may be of the belt type. In this case, the front chainring, rear sprocket and belt are supplied by the belt's manufacturer. Also, for details concerning assembly and adjustment, refer to the technical information provided by the belt manufacturer.
- For information on how to install MU-S705, refer to "Installation of the motor unit to the hub (MU-S705)" in the dealer's manual for the ALFINE S705 series.
- **Maximum cable length (EW-SD50)**  
(a) ≤ 1600 mm

**Product specifications**

Operating temperature range: During discharge	-10 – 50 °C	Battery type	Lithium Ion Battery
Operating temperature range: During charging	0 – 40 °C	Nominal capacity	Refer to the user's manual for the battery "UM-70F0A". For the latest information on manuals, see the website ( <a href="http://si.shimano.com">http://si.shimano.com</a> ).
Storage temperature	-20 – 70 °C	Rated voltage	36 V DC
Storage temperature (Battery)	-20 – 60 °C	Drive unit type	Midship
Charging voltage	100 – 240 V AC	Motor type	Brush-less DC
Charging time	Refer to the user's manual for the battery "UM-70F0A". For the latest information on manuals, see the website ( <a href="http://si.shimano.com">http://si.shimano.com</a> ).	Rated drive unit power	250W

\* The range of the assist function speed is different depending on the specifications.

DU-E6000/E6001/E6010: 25km/h or less

DU-E6050: 20mile/h or less

## ■ Installing the cycle computer

**1** Open the clamp **(B)** and attach it to the handlebar.

Attach the handlebar fixing bolt **(A)** and tighten to the specified tightening torque using a screwdriver.

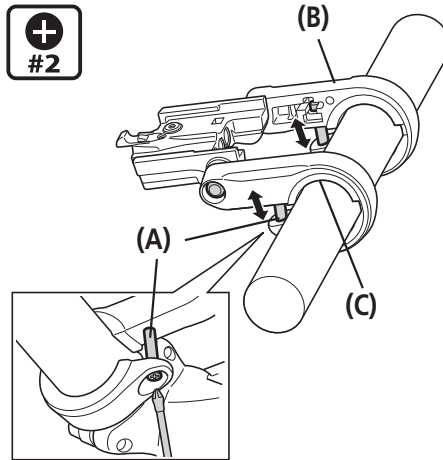

- (A)** Handlebar fixing bolt
- (B)** Clamp
- (C)** Adapter

**Handlebar compatibility table**

øA	øB-øA	Adapter	Fixing bolt
ø23.4-ø24	0-1.1	X	15.5mm
ø24-ø25.5	0-1.1	X	20mm
ø31.3-ø31.9	0-0.6	-	20mm

\*X: OK

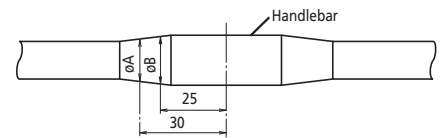

When removing the cycle computer, reverse the procedure.



**Tightening torque:**  
**1 N·m**

**2**

## INSTALLATION

### ▶▶ Installing and removing the cycle computer

## ■ Installing and removing the cycle computer

1

Slide the cycle computer (A) into the bracket (B) as shown in the illustration. Insert it firmly until you hear it click.

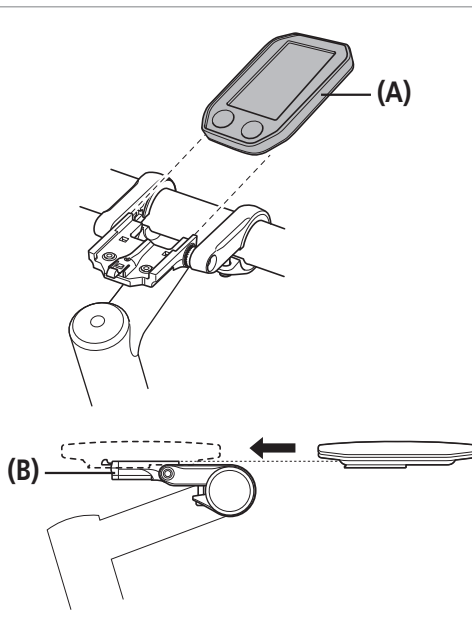

(A) Cycle computer

(B) Bracket

2

To remove the cycle computer, slide it while pushing the bracket lever (C).

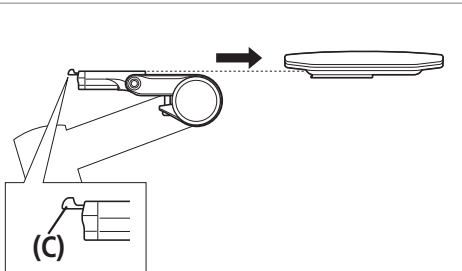

(C) Lever

### NOTE

- If the cycle computer is not in the correct place, the assist function will not operate normally.
- The dimensions of (C) differ for SC-E6000 and SC-E6010.

## ■ Adjusting the angle of the cycle computer

Loosen the angle adjustment screw (A) with a screwdriver. Adjust the angle of the cycle computer to make it easier to see while riding.

After determining the angle, tighten the screw to the designated torque.

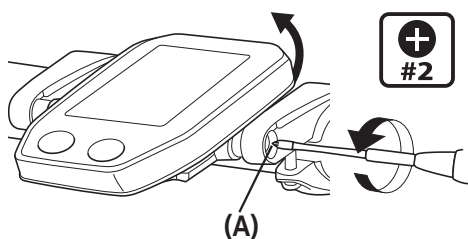

(A) Angle adjustment screw

(A)  #2

Tightening torque:  
0.5 N·m

## INSTALLATION

►► Using the cable band to attach the assist switch to the handlebar

### ■ Using the cable band to attach the assist switch to the handlebar

1

Temporarily attach the cable band (A) to the assist switch. Adjust the cable band according to the length of the handlebar.

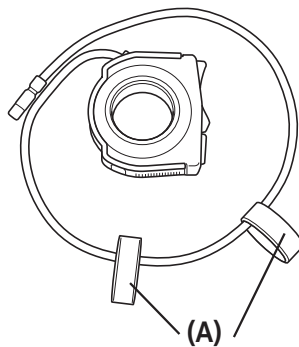

(A) Cable band



TECH TIPS

The cable band is included in SW-E6000.

2

Attach the assist switch mounted with the cable band to the handlebar.

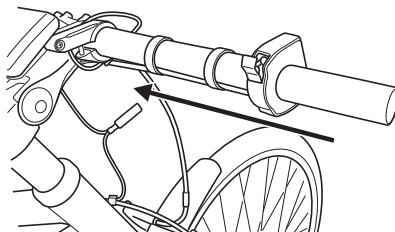

### ■ Installing the assist switch

1

Attach the assist switch to a  $\phi 22.2$  handlebar with the electric wire routed under the switch and open the fixing bolt cover (A).

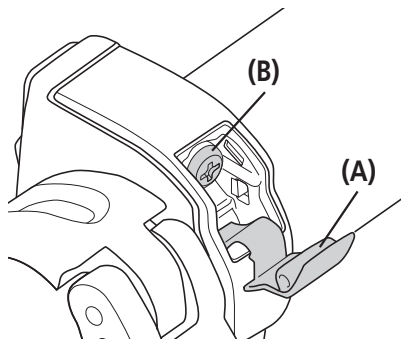

(A) Fixing bolt cover

(B) Fixing bolt

2

Tighten the fixing bolt (B) to the specified tightening torque using a screwdriver.

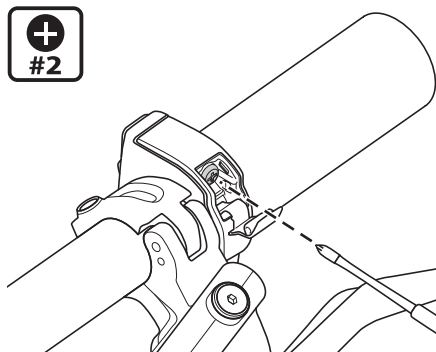

TECH TIPS

When removing the cycle computer, reverse the procedure.

(B)  Tightening torque:  
1.5 N·m

**Example of routing the electric wire**

**Example 1:** Secure the electric wire of the assist switch (A) to the handlebar using the cable band (B). Wind the excess electric wire around the area between the cycle computer (C) and stem (D), then connect the wire to the cycle computer.

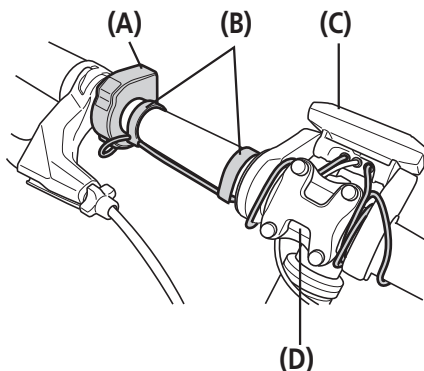

- (A) Assist switch
- (B) Cable band
- (C) Cycle computer
- (D) Stem

**Example 2:** Secure the electric wire of the assist switch to the handlebar using the cable band. Bind the electric wire of the assist switch and that of the cycle computer (E) to the brake outer casing (F) using the band (G) and connect the electric wire of the assist switch to the cycle computer.

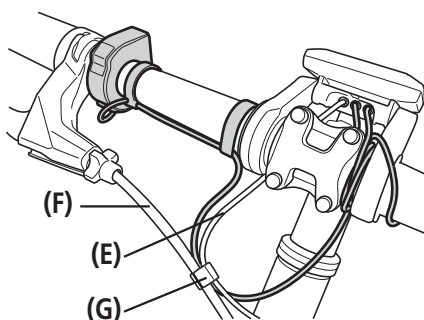

- (E) Electric wire of the cycle computer
- (F) Brake outer casing
- (G) Band

 **TECH TIPS**

The band is included in SC-E6000.



**■ Installing the battery mount**

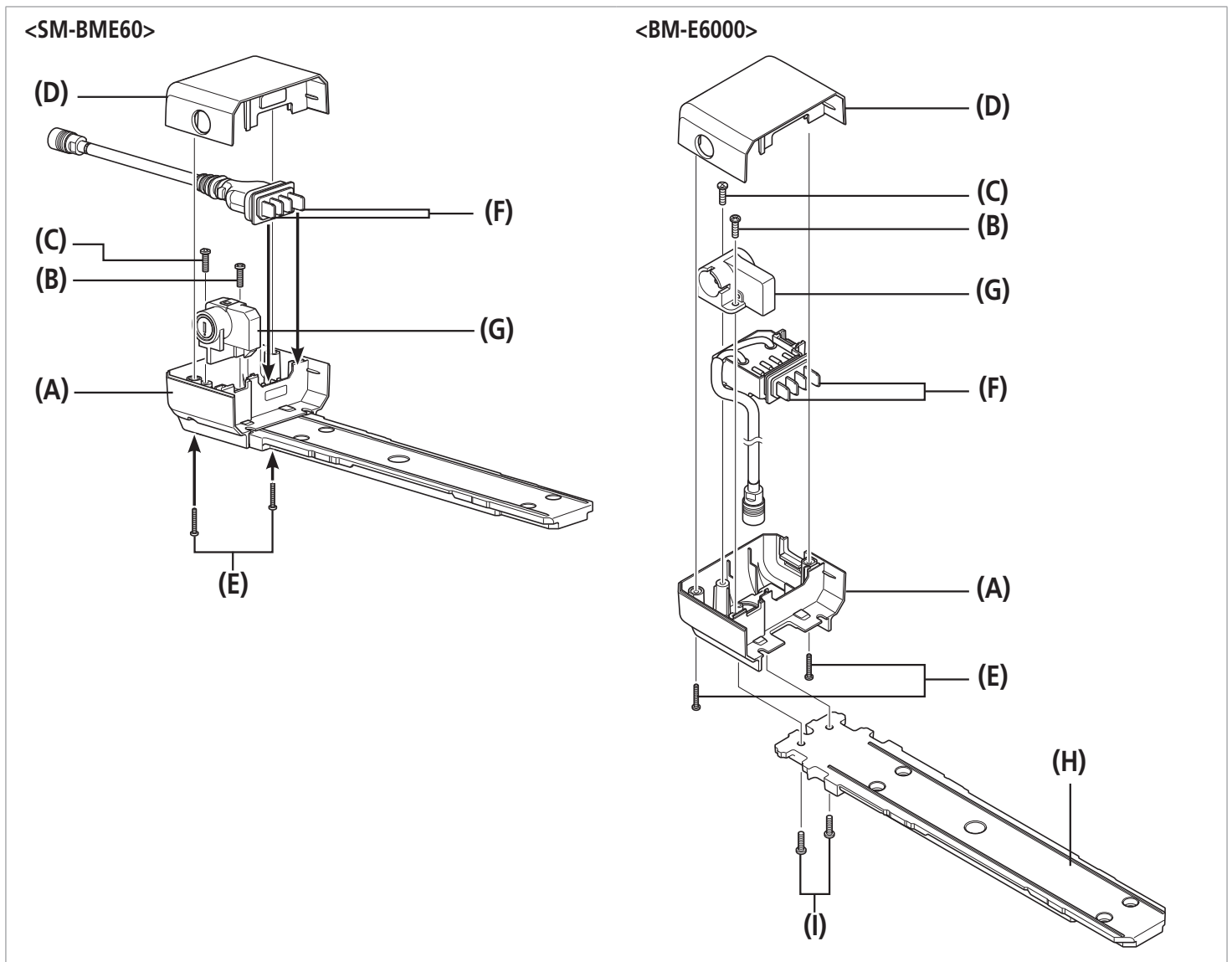

**SM-BME60 / BM-E6000**



- (A) Mount lower case
- (B) M4 bolt
- (C) M4 bolt (one-way type)
- (D) Mount upper case
- (E) Hexalobular #10H

- (F) Plug
- (G) Key unit (not included with the product)
- (H) Battery mount rail
- (I) M4 bolt

**<For SM-BME60>**

<b>1</b>	Secure the key unit (G) to the mount lower case (A) by tightening M4 bolt (B) and (C).	 	<b>Tightening torque:</b> 1.6 - 1.8 N·m
<b>2</b>	Align the plug (F) with the mount lower case (A).		
<b>3</b>	Assemble the mount upper case (D) with the mount lower case (A) by 2 bolts (E).		<b>Tightening torque:</b> 1 - 1.3 N·m

## INSTALLATION

### ▶▶ Installing the battery mount

<For BM-E6000>

1

Secure the key unit (G) to the mount lower case (A) by tightening M4 bolt (B) and (C).

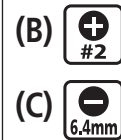

Tightening torque:  
1.6 - 1.8 N·m

2

Align the plug (F) and battery mount rail (H), in that order, with the mount lower case (A).

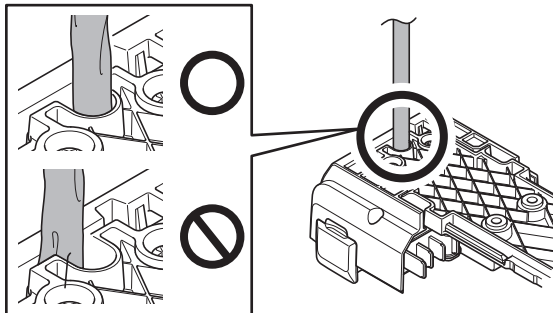

3

Mount the mount lower case (A) and the battery mount rail (H) using the M4 bolt (I).



Tightening torque:  
1.6 - 1.8 N·m

4

Assemble the mount upper case (D) with the mount lower case (A) by 2 bolts (E).



Tightening torque:  
1.1 - 1.3 N·m

Align the mounting holes in the carrier with those in the battery mount. Insert hexagon socket head cap screws (A) into the upper part of the battery mount and tighten it to the carrier.

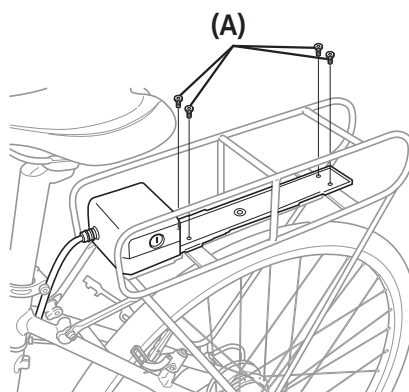

(A) Hexagon socket head cap screw (M5) (not included with the product)

### NOTE

Make sure that the charging port cap is closed securely.

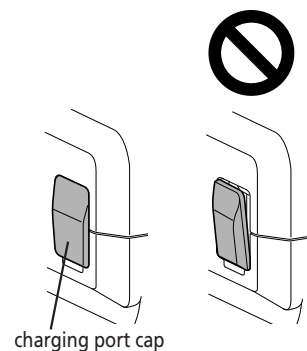

### TECH TIPS

Bolts and nuts are not included with Shimano products. Use those supplied by the manufacturer.

For information on the tightening torques, contact the manufacturer of the carrier.

**SM-BME61 / BM-E6010**

**1**

Attach the mount lower case (E) to the mounting holes in the frame, insert the mount fixing bolts (C) into the washers (D), and secure the case using the bolts. Then, temporarily attach the key unit (B) with the key unit fixing bolts (A).

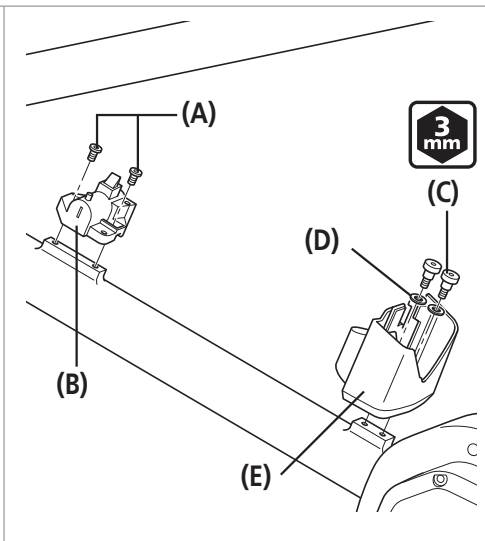

- (A) Key unit fixing bolt (M5)
- (B) Key unit (not included with the product)
- (C) Mount fixing bolt (M5)
- (D) Washers
- (E) Mount lower case

(C) 	<b>Tightening torque:</b> 3 N·m
---	------------------------------------

**NOTE**

Key unit is not included with Shimano products.

**2**

Adjust the position of the key unit to allow a clearance of 223 mm between (a) and (b) shown in the illustration. Temporarily attach the key unit cover and perform adjustment to make sure that the battery can be smoothly connected and disconnected and no noise will be produced due to looseness during traveling. Then, fully tighten the key unit fixing bolts.

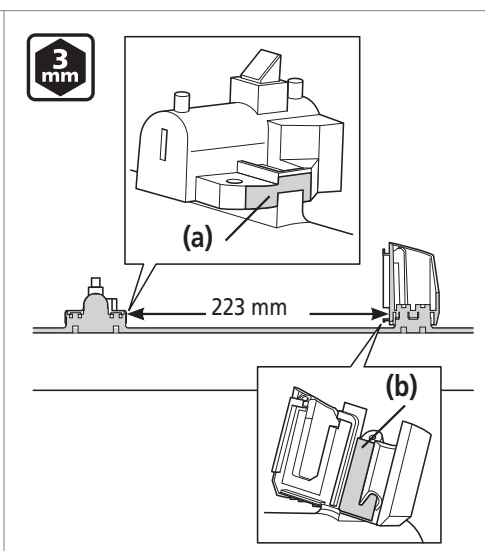

(A) 	<b>Tightening torque:</b> 3 N·m
---	------------------------------------

3

<SM-BME61>

Fully tighten the key unit cover fixing bolts (J) to attach the key unit cover (I).

Mount the battery rattle prevention spacer (K). When mounting the battery rattle prevention spacer (K), peel the release liner off the double-sided seal (L) on the back of the battery rattle prevention spacer and mount.

Insert the plug (F) into the mount lower case (M). Insert the plug (F) between the mount upper case (G), and secure them using the mount upper case fixing bolts (H).

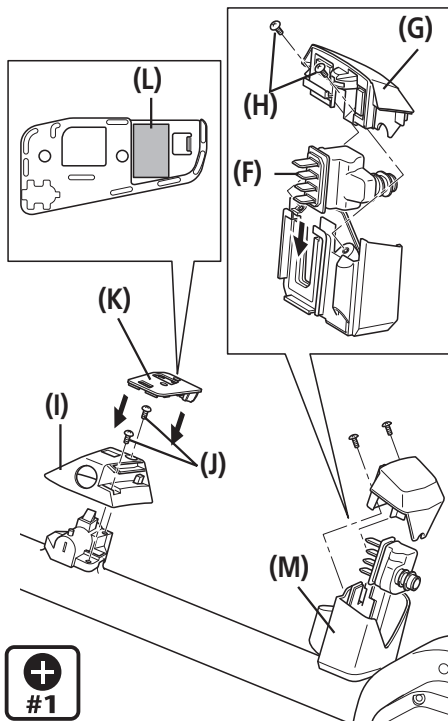

- (F) Plug
- (G) Mount upper case
- (H) Mount upper case fixing bolt (M3)
- (I) Key unit cover
- (J) Key unit cover fixing bolt (M4)
- (K) Battery rattle prevention spacer
- (L) Double-sided seal
- (M) Mount lower case
- (N) Charging port cap

(H) (J)		<b>Tightening torque:</b> 0.6 N·m
------------	--	--------------------------------------

**NOTE**

- Check that there is no oil, foreign objects, etc., on the adhesive surface of the double-sided seal (L) or on the surface to which the double-sided seal (L) is to be attached. If there is, remove it.
- For BM-E6010, make sure to pull open the charging port cap (N) fully before inserting the plug (F), as in the illustration. Inserting the plug with the cap closed will disrupt the proper opening/closing of the cap.

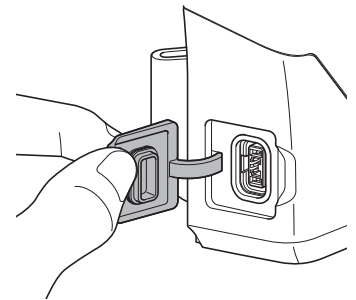

- Make sure that the charging port cap is closed securely.

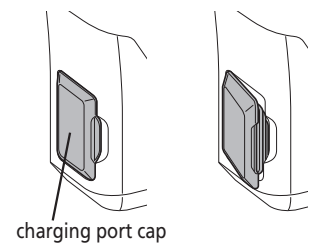
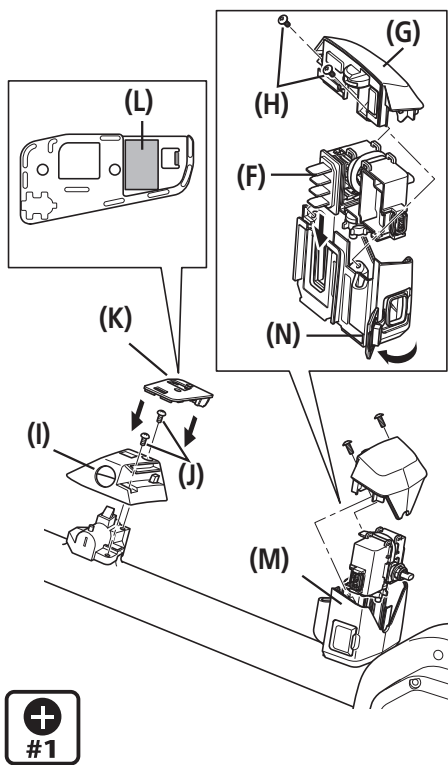

**BM-E8010**

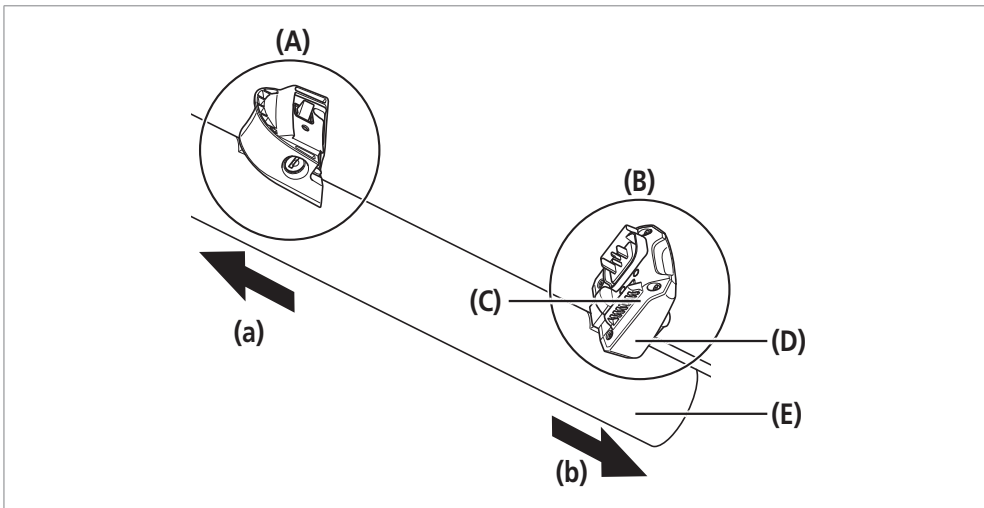

**(a)** Front of bicycle

**(b)** Rear of bicycle

**(A)** Key unit

**(B)** Battery connection unit

**(C)** Mount upper case

**(D)** Mount lower case

**(E)** Frame

Set in place the rubber spacers (C) and metal spacer (B) on the mount lower case (A) and align the frame mounting holes (E) with the bolt holes in the mount lower case (A).

**1**

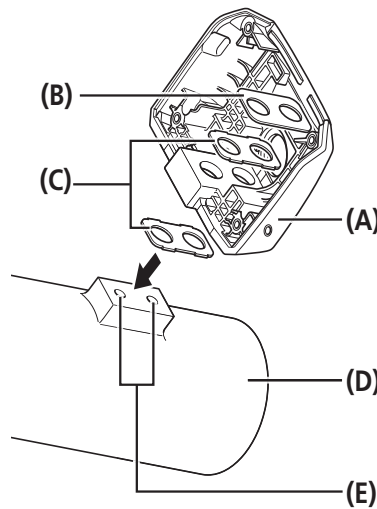

**(A)** Mount lower case

**(B)** Metal spacer

**(C)** Rubber spacer

**(D)** Frame

**(E)** Frame mounting holes

## INSTALLATION

### ▶▶ Installing the battery mount

2

Secure the mount lower case (H) by tightening the two types of mount fixing bolt (M5) (F)/(G).

Tighten the mount fixing bolt (M5) (low head type) (G) first.

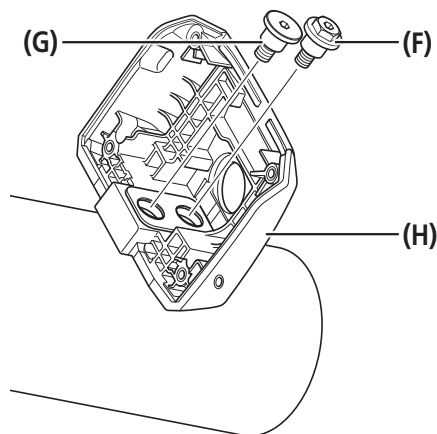

- (F) Mount fixing bolt (M5) (hexagon bolt type):  
Use a 3mm hexagon wrench or 8mm spanner on the mount fixing bolt.
- (G) Mount fixing bolt (M5) (low head type):  
Use a 3mm hexagon wrench on the mount fixing bolt.
- (H) Mount lower case



Tightening torque:  
3 N·m

3

Temporarily attach the key unit with the key unit fixing bolts (M5) (J).

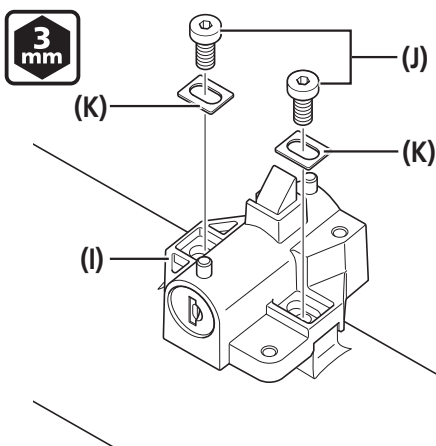

- (I) Key unit:  
Key unit is not included with Shimano products.
- (J) Key unit fixing bolt (M5)
- (K) Washer

4

Adjust the position of the key unit so that the distance between section (a) of the key unit and section (b) of the mount lower case is 224.4mm and then fully tighten the key unit fixing bolts (M5) (J).

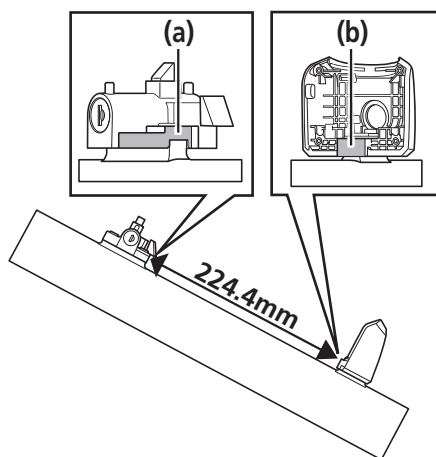

Tightening torque:  
3 N·m

**5**

Temporarily attach the key unit cover (L) to the key unit and adjust so that the battery (M) can be smoothly connected/ disconnected and no noise is produced due to looseness during riding.

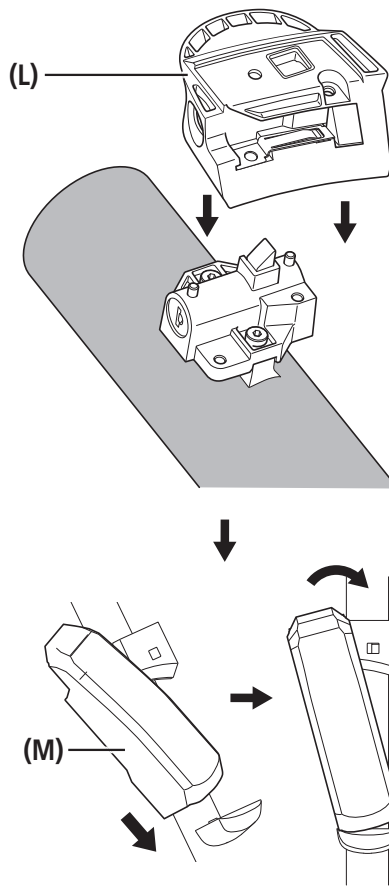

(L) Key unit cover

(M) Battery

**6**

Secure the key unit cover with the key unit cover fixing bolts (M4) (O).

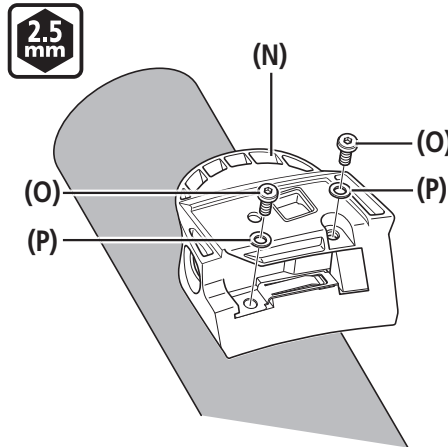

(N) Key unit cover

(O) Key unit cover fixing bolt (M4)

(P) Washer



Tightening torque:  
0.6 N·m

## INSTALLATION

### ▶▶ Installing the battery mount

# 7

Route the battery cable (Q) through the cable routing hole (R).

Align the protruding parts of the mount upper case (S) and mount lower case (T).

Pull the battery cable (Q) until the rubber bush (U) is implanted in the cable routing hole (R).

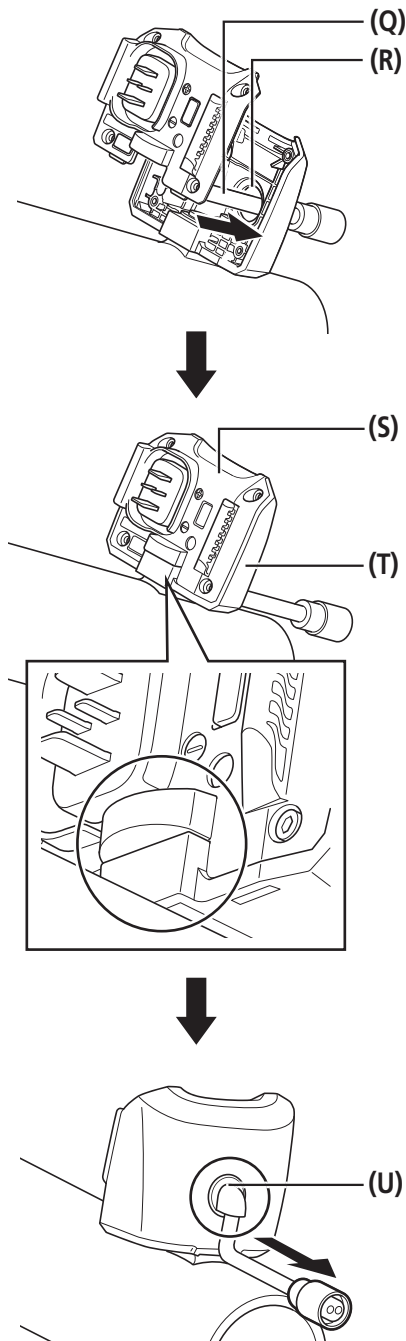

- (Q) Battery cable
- (R) Cable routing hole
- (S) Mount upper case
- (T) Mount lower case
- (U) Rubber bush

# 8

Tighten on the mount upper case (V) using the mount upper case fixing bolts (M3) (W).

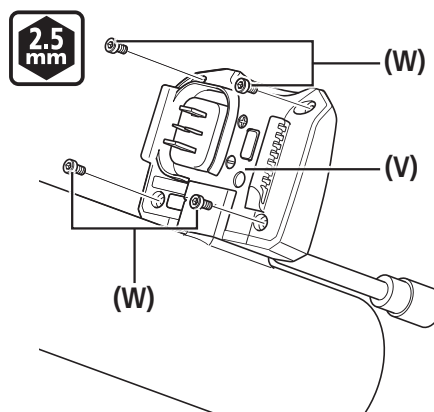

- (V) Mount upper case
- (W) Mount upper case fixing bolt (M3)

(X)  Tightening torque:  
0.6 N·m



**BM-E8020**

**Assembly of the battery connection unit**

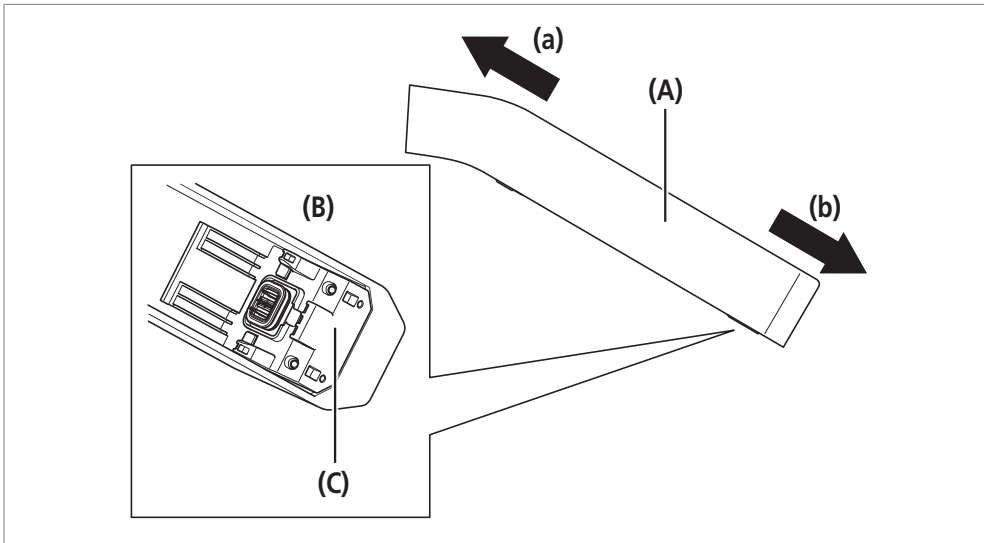

**(a)** Front of bicycle

**(b)** Rear of bicycle

**(A)** Frame

**(B)** Battery connection unit

**(C)** Mount upper case and mount lower case when assembled

Set in place the rubber spacer (B) on the mount lower case (A) and align the frame mounting holes (D) with the bolt holes in the mount lower case (A).

**1**

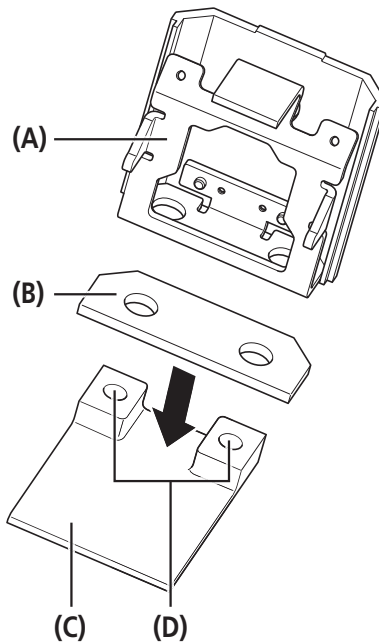

**(A)** Mount lower case

**(B)** Rubber spacer

**(C)** Frame

**(D)** Frame mounting holes

## INSTALLATION

### ▶▶ Installing the battery mount

# 2

Secure the mount lower case (F) to the frame by the tightening the mount fixing bolts (M8) (E).

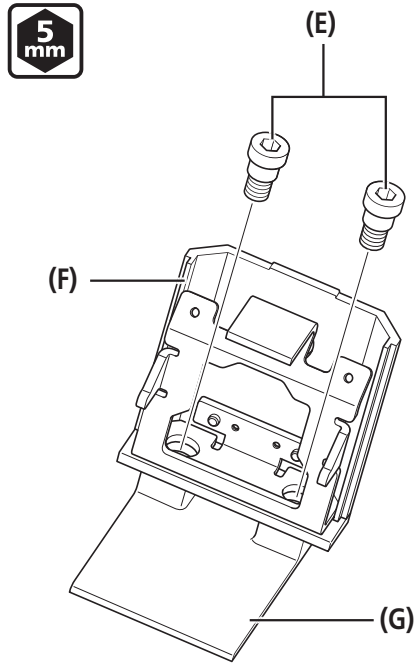

- (E) Mount fixing bolt (M8)
- (F) Mount lower case
- (G) Frame

(E)  Tightening torque:  
10 N·m

# 3

Route the battery cable (I) through the cable routing hole (K) in the mount lower case (J) and then tighten on the mount upper case (H) using the mount upper case fixing bolts (M3) (L).

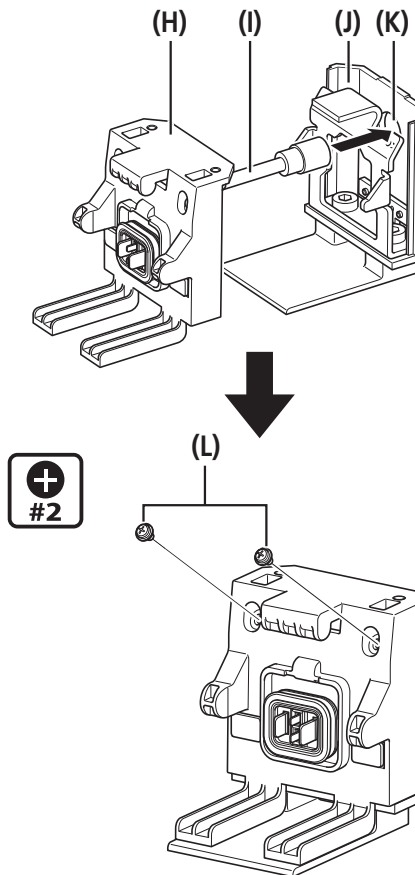

- (H) Mount upper case
- (I) Battery cable
- (J) Mount lower case
- (K) Cable routing hole
- (L) Mount upper case fixing bolt (M3)

(L)  Tightening torque:  
0.6 N·m

## INSTALLATION

### ▶▶ Installing the battery mount

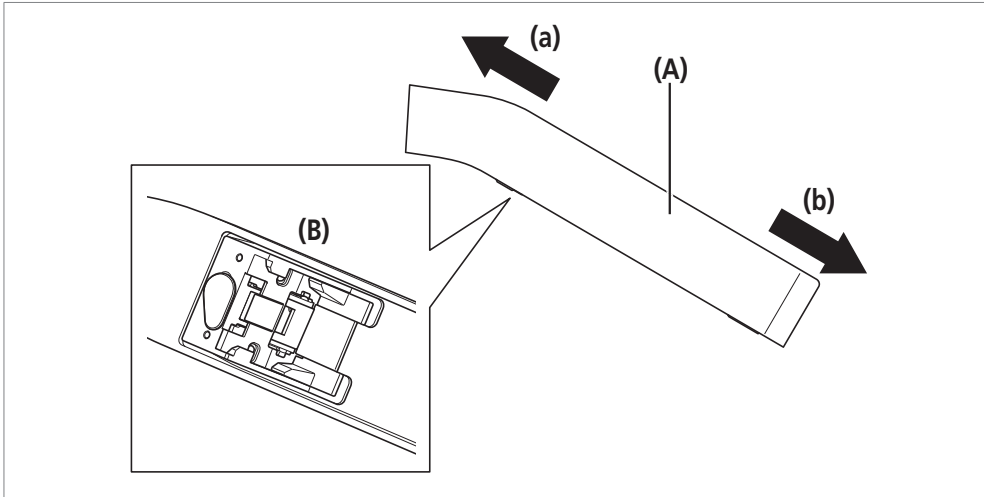

(a) Front of bicycle

(b) Rear of bicycle

(A) Frame

(B) Key unit

Insert the key cylinder (M) into the key unit.

Secure the key cylinder (M) in place by tightening the key cylinder fixing bolts (M4) (O) from the reverse side of the key unit (N).

(a) Reverse side of key unit

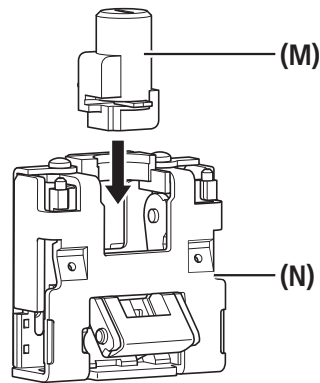

(M) Key cylinder:  
Key cylinder is not included with Shimano products.

(N) Key unit

(O) Key cylinder fixing bolt (M4)

(O)  Tightening torque:  
0.6 N·m

4

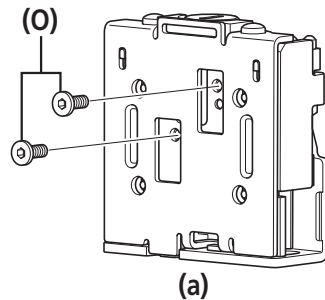

## INSTALLATION

### ▶▶ Installing the battery mount

5

Align the fixing bolt holes in the key unit (P) with the frame mounting holes (T).

Temporarily attach the key unit (P) to the frame (S) with the key unit fixing bolts (M8) (Q).

Attach the bolt dropout prevention rubbers (R).

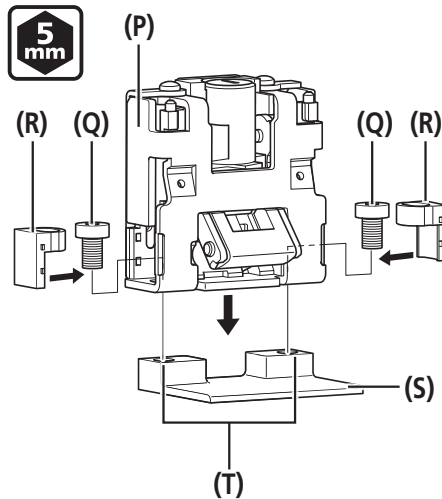

- (P) Key unit
- (Q) Key unit fixing bolt (M8)
- (R) Bolt dropout prevention rubber
- (S) Frame
- (T) Frame mounting holes

6

Adjust the position of the key unit so that the distance between section (c) of the key unit and section (d) of the battery connection unit is **347.9mm** and then fully tighten the key unit fixing bolts (Q).

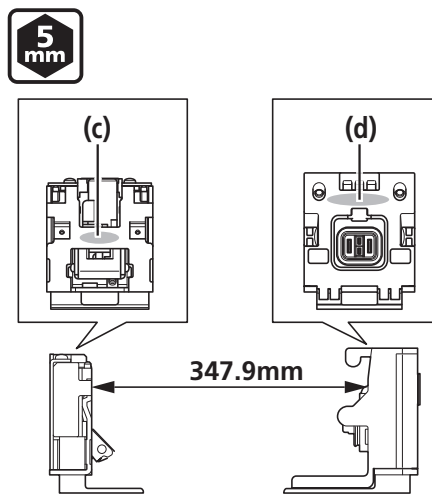

- (Q)  Tightening torque:  
10 N·m

7

Temporarily attach the key unit cover (U) to the key unit and adjust so that the battery (V) can be smoothly connected/disconnected and no noise is produced due to looseness during riding.

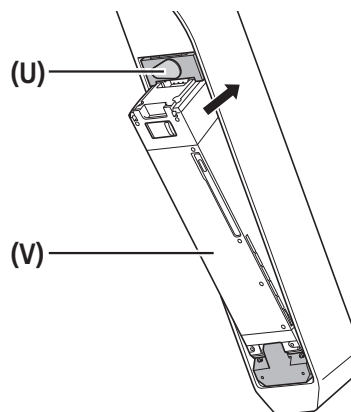

- (U) Key unit cover
- (V) Battery

## INSTALLATION

### ▶▶ Installing the battery mount

#### Attaching/detaching the battery on downward attachment/removal design frames

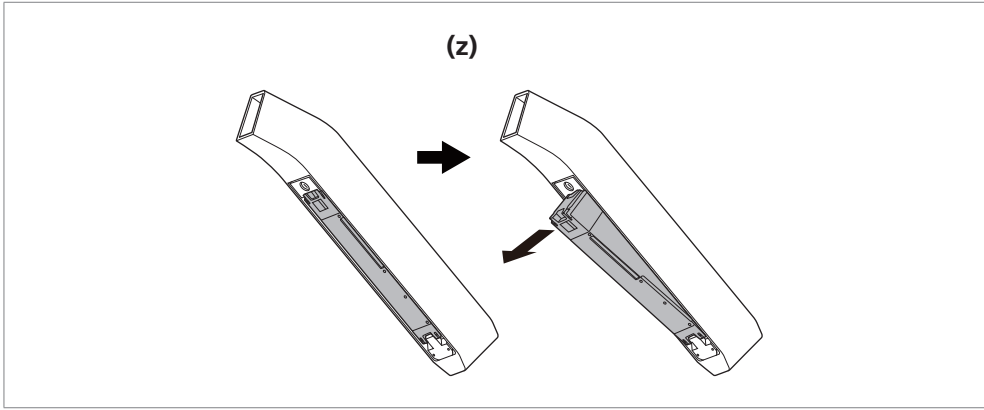

(z) Downward attachment/  
removal design frame

8

Use key unit cover A (W) with the indication marking A and make sure to attach the plate spring (Z).

Attach key unit cover A (W) to the key unit (X).

Secure in place the key unit (X) with the key unit cover fixing bolts (M3) (Y).

Secure the plate spring (Z) in place by tightening the plate spring fixing bolt (AA).

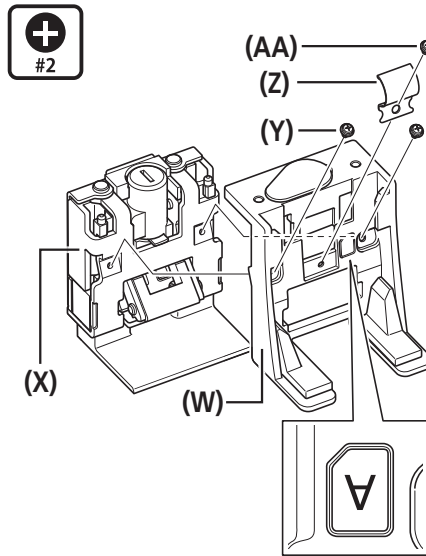

(W) Key unit cover A  
(X) Key unit  
(Y) Key unit cover fixing bolt (M3)  
(Z) Plate spring  
(AA) Plate spring fixing bolt

(Y) (AA) #2 Tightening torque:  
0.6 N·m

**Attaching/detaching the battery on upward attachment/removal design frames**

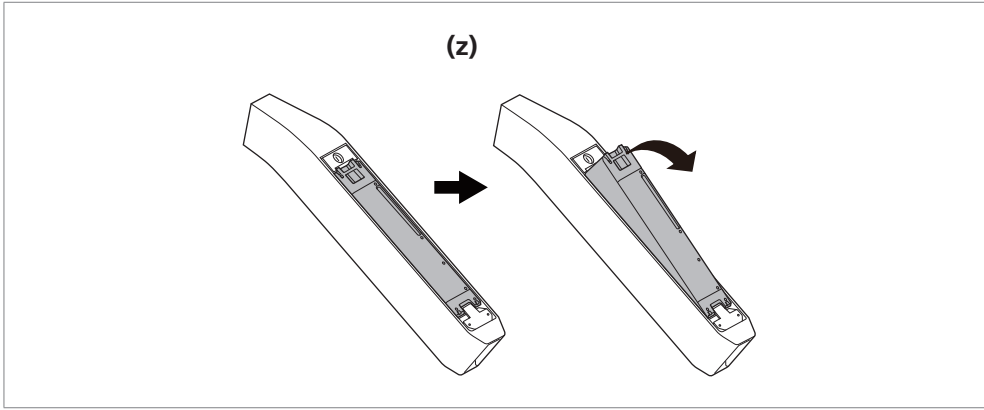

**(z)** Upward attachment/  
removal design frame

**8**

Make sure to use key unit cover B **(AB)** with the indication marking B.

Attach key unit cover B **(AB)** to the key unit **(AC)**.

Secure in place the key unit **(AC)** with the key unit cover fixing bolts (M3) **(AD)**.

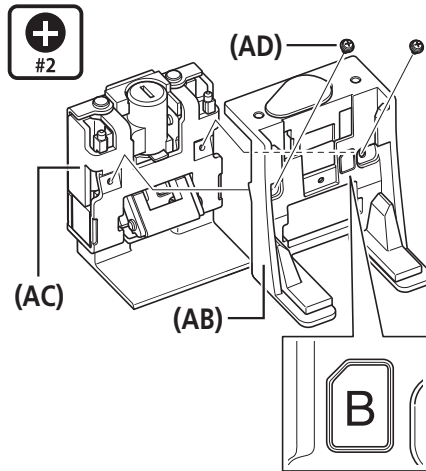

**(AB)** Key unit cover B

**(AC)** Key unit

**(AD)** Key unit cover fixing bolt (M3)

**(AD)**  **#2** Tightening torque:  
0.6 N·m

**NOTE**

Do not attach a plate spring when using an upward attachment/removal design frame.

## INSTALLATION

### ▶▶ Installing the battery

## ■ Installing the battery

### BT-E6000/BT-E6001/SM-BME60/BM-E6000

Set the battery on the mount rail from behind and slide it forward. Push it firmly into place.

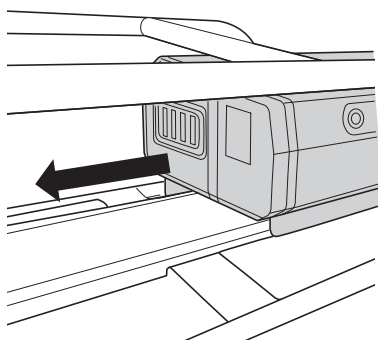

#### NOTE

To prevent the battery from falling off, check to see that the battery is locked after installation.

### BT-E6010/SM-BME61/BM-E6010/BT-E8010/BM-E8010

1

Align the indentation in the bottom of the battery with the protrusion on the mount and insert the battery.

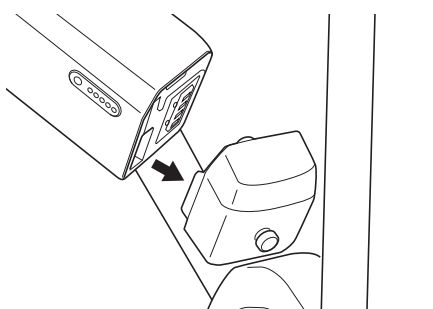

2

Slide the battery to the right starting from the point where it is inserted. Push it firmly into place.

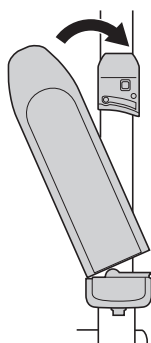

#### NOTE

- To prevent the battery from falling out, check to see that the battery is locked after installation.
- Before riding, make sure that the charging port cap is closed.
- To prevent the battery from falling out, do not ride the bicycle with the key inserted.

## INSTALLATION

### ▶▶ Installing the battery

## BT-E8020/BM-E8020

For the purposes of demonstration, these instructions take as an example a frame design where the battery is removed/installed from below.

Insert the battery **(A)** into the battery mount **(B)** until there is a click.

- When inserted until a click is heard, the battery is locked automatically.

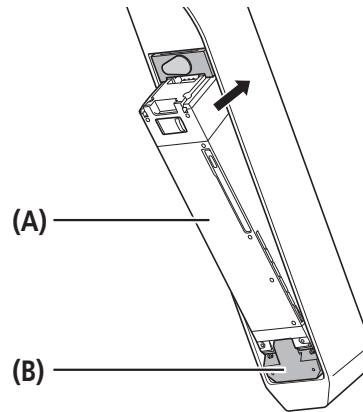

**(A)** Battery

**(B)** Battery mount

### NOTE

- To prevent the battery from falling out, check to see that the battery is locked after installation.
- Before riding, make sure that the keyhole cap and charging port cap are closed.
- To prevent the battery from falling out, do not ride the bicycle with the key inserted.

Keyhole cap

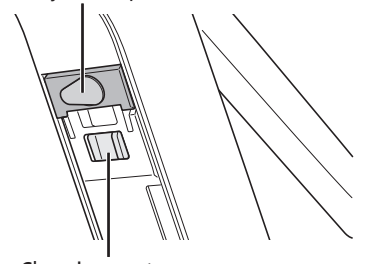

Charging port cap



## ■ Removing the battery

BT-E6000/BT-E6001/BT-E6010/BT-E8010

The following description may not be applicable as different types of keys are available.

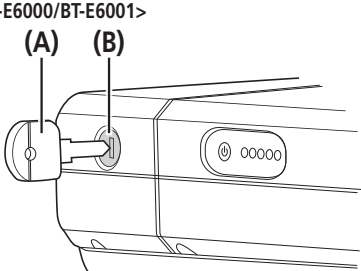
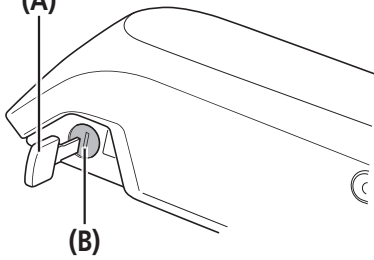
<b>1</b>	<p>Turn off the power, then insert the key (A) into the key cylinder (B) in the battery holder.</p>	<p>&lt;BT-E6000/BT-E6001&gt;</p>  <p>&lt;BT-E6010/BT-E8010&gt;</p> 
----------	---	--

- (A) Key
- (B) Key cylinder

 **TECH TIPS**

- The position of the key does not affect the insertion of the battery. You can insert it regardless of the key position.
- You cannot remove the key when it is not in the inserting position.

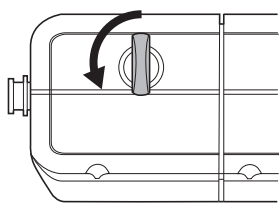
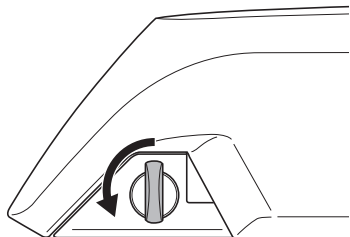
<b>2</b>	<p>To unlock the battery turn the key (A) to the left until you feel some resistance.</p>	<p>&lt;BT-E6000/BT-E6001&gt;</p>  <p>&lt;BT-E6010/BT-E8010&gt;</p> 
----------	---	--

<b>3</b>	<p>Pull out the battery.</p>	<p>&lt;BT-E6000/BT-E6001&gt;</p> 
----------	------------------------------	---

 **TECH TIPS**

- You can remove the battery only when the key is in the unlocking position.

## INSTALLATION

### ▶▶ Removing the battery

3

Hold the upper part of the battery and slide it to the left to remove it.

<BT-E6010/BT-E8010>

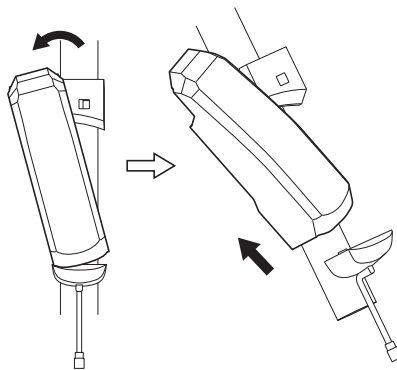

## NOTE

Hold the battery firmly and be careful that it does not drop when removing or carrying it.

## BT-E8020

- For the purposes of demonstration, these instructions take as an example a frame design where the battery is removed/installed from below.
- If using a battery cover manufactured by another company, remove the battery cover before removing the battery.

1

Remove the keyhole cap (A).

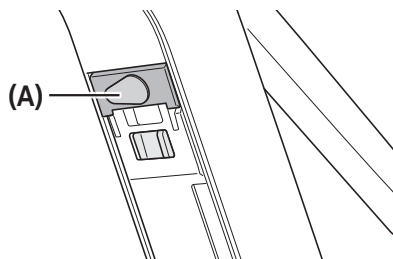

(A) Keyhole cap

2

Insert the key (B) into the key cylinder (C) in the battery mount.

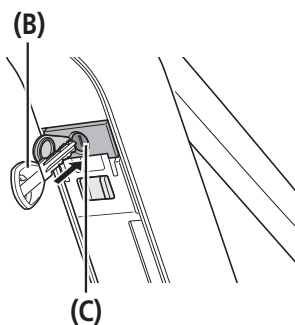

(B) Key  
(C) Key cylinder

## TECH TIPS

- The position of the key does not affect the insertion of the battery. You can insert it regardless of the key position.
- You cannot remove the key when it is not in the inserting position.

3

To unlock the battery, turn the key (B) clockwise and push it in. When the battery lock is unlocked, the plate spring holds the battery in place, preventing it from falling out.

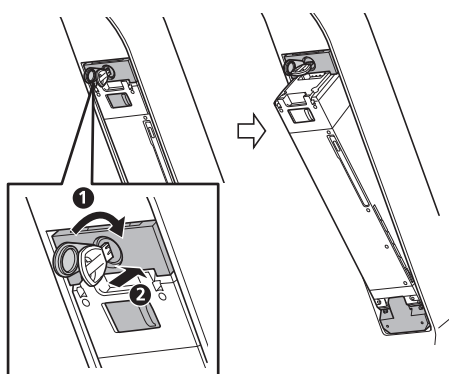

## INSTALLATION

### ▶▶ Removing the battery

4

Remove the key (B) from the key cylinder (C), close the keyhole cap (A), and detach the battery.

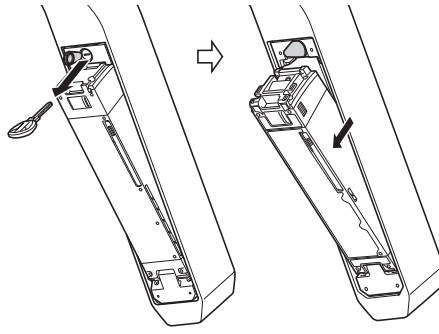

## NOTE

- Support the battery with your hand when detaching to make sure that it does not fall out.
- Do not attach or detach the battery with the key left inserted into the key cylinder or the keyhole cap left open. The battery may be damaged from contact with the handle of the key or the keyhole cap.

**■ Installing the speed sensor**

**1**

Before installing the speed sensor (A), check that the clearance (a) between the speed sensor and the magnet unit (B) will be within 3 to 17 mm.

- (A) Speed sensor
- (B) Magnet unit
- (C) Spoke
- (D) Chain stay

**TECH TIPS**

When checking the clearance is within 17 mm, take wheel truing, frame distortion, etc. into account.

**2**

If the clearance is within the designated range, place the toothed washer (E) between the speed sensor and the chain stay, then attach the speed sensor fixing bolt (F).

- (E) Toothed washer
- (F) Speed sensor fixing bolt (16 mm)

(F) **Tightening torque:**  
1.5 - 2 N·m

**3**

If the clearance exceeds 17mm, use a spacer (G) to adjust it. Attach the speed sensor with the speed sensor fixing bolt (H).

- (G) Spacer
- (H) Speed sensor fixing bolt (22 mm)

(H) **Tightening torque:**  
1.5 - 2 N·m

## INSTALLATION

### ▶▶ Mounting the magnet

## ■ Mounting the magnet

### Magnet mounting position

Mount the magnet so that its center is aligned over the apex of the triangle symbol.

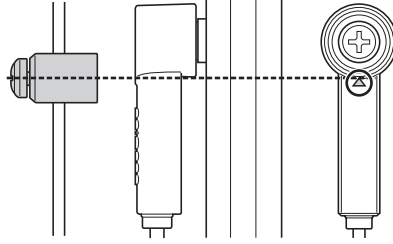

### How to mount the magnet

1

Align the speed sensor (A) and magnet unit (B) as shown in the illustration.

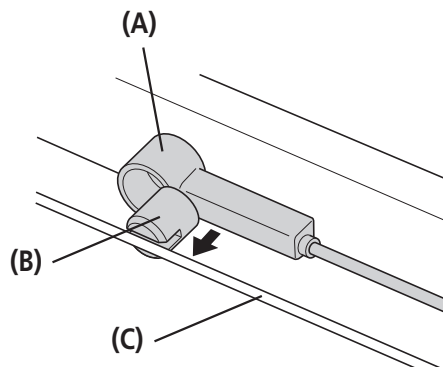

- (A) Speed sensor
- (B) Magnet unit
- (C) Spoke

2

Tighten the mounting screw (D) with a screwdriver.

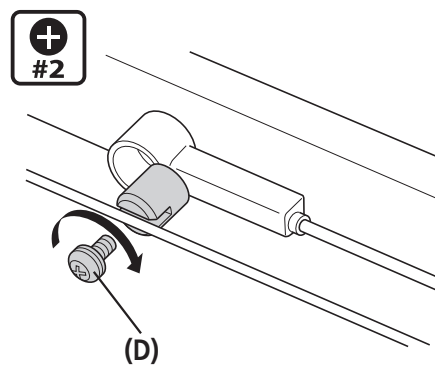

- (D) Mounting screw

(D)  #2 Tightening torque:  
1.5 - 2 N·m

# **INSTALLING AND WIRING THE DRIVE UNIT**

# INSTALLING AND WIRING THE DRIVE UNIT

## ■ Installing the drive unit

1

Align the three mounting holes (B) in the drive unit (A) with those in the frame.

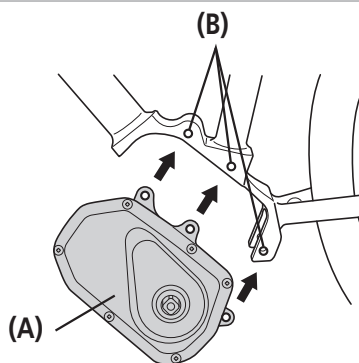

- (A) Drive Unit
- (B) Mounting holes

### NOTE

Be careful not to pinch the cables with the frame or drive unit case.

2

Insert M8 bolts, attach nuts from the opposite side, and tighten them to the designated torque.

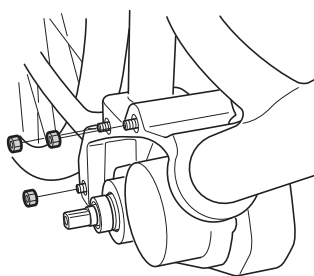

### TECH TIPS

Bolts and nuts are not included with Shimano products. Use those supplied by the manufacturer. For information on the tightening torques, contact the manufacturer.

## ■ Drive unit wiring diagram

Below is an example of wiring on a carrier type battery.

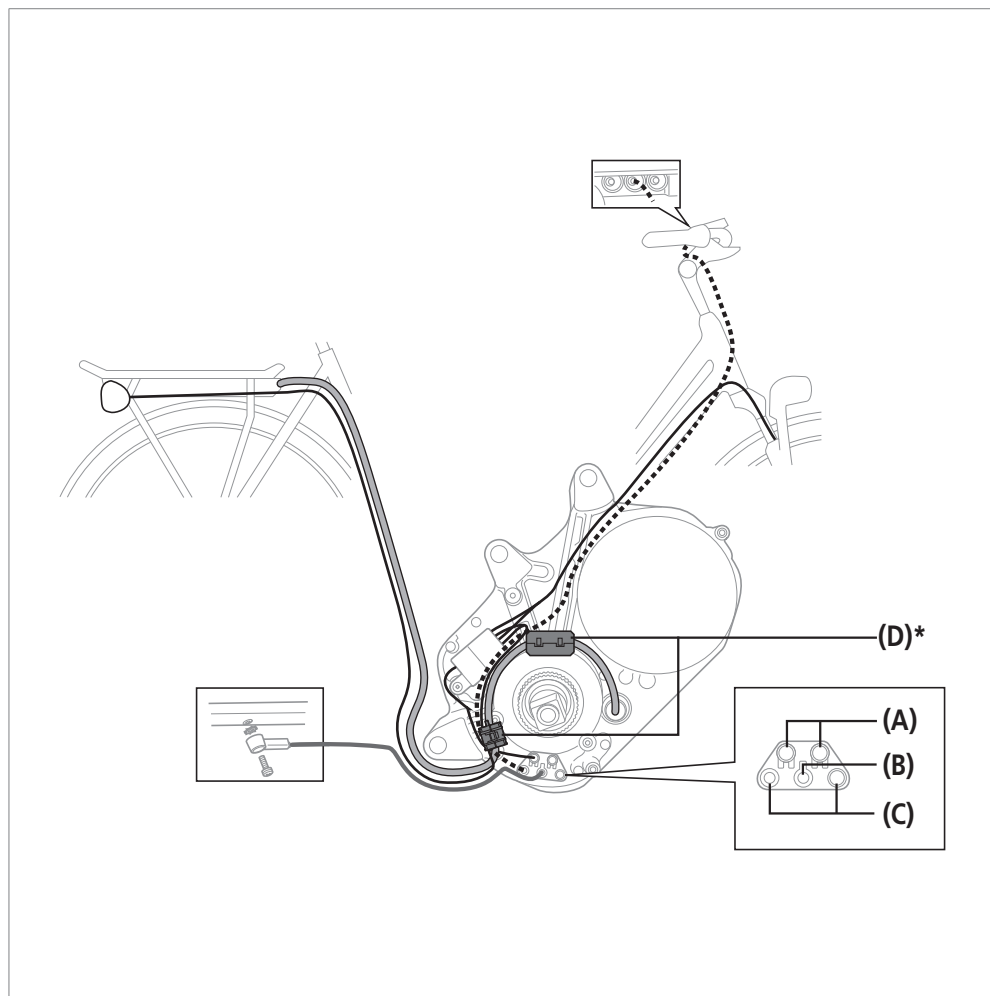

- (A) Light connector
- (B) Speed sensor connector
- (C) E-TUBE connector for cycle computers and motor units
- (D) Ferrite core\*

\* May not be included, depending on the product's specifications.

### NOTE

Be sure to attach dummy plugs to any unused ports.

### TECH TIPS

- The left illustration shows an example of wiring.

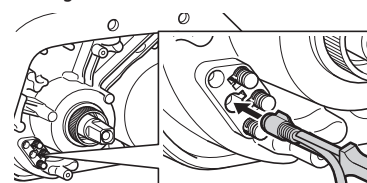

- The light connector can be used through both ports (A).
- The E-TUBE connector for cycle computers and motor units can be used through both ports (C).

▶▶ Connecting the power cord

■ **Connecting the power cord**

**Connecting to the drive unit**

Align the arrow on the power cord connector (A) with the triangle symbol on the drive unit receptacle (B) and insert the power cord. Insert it until it locks into place.

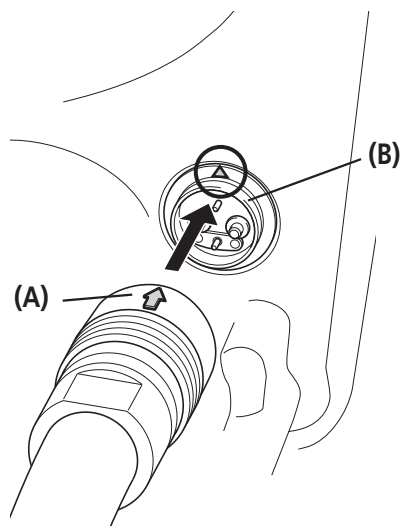

(A) Power cord connector

(B) Drive unit receptacle

**Disconnecting from the drive unit**

To remove the power cord, hold it by the grooved part of its end and pull it towards yourself.

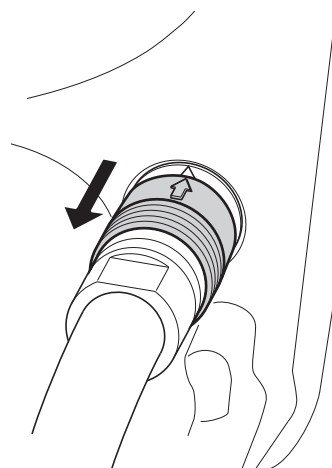



## ■ Installing the ferrite core (DU-E6001/E6010/E6050)

If a ferrite core is included with drive unit, install it by following the procedure described below.

Depending on the specifications, a ferrite core may not be included with drive unit, so installation is not required.

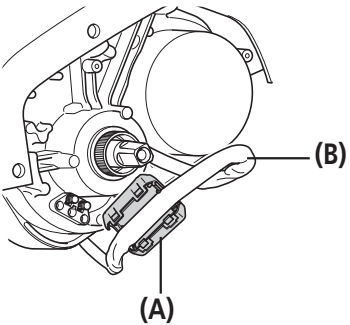
1	<p>Install the ferrite core (A) on the power cord (B).</p>	
---	--	--

- (A) Ferrite core
- (B) Power cord

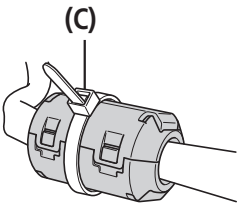
2	<p>Make sure that the power cord is not pinched and firmly secure the ferrite core. Then, fix the ferrite core with the zip tie (C).</p>	
---	--	---

- (C) Zip tie

**NOTE**

- Check that the ferrite core tabs are firmly secured.
- Do not cut off the excess portion of the zip tie. The cut surface of the zip tie may scratch the cable or case.
- Do not drop the ferrite core or subject it to any shocks. Subjecting the ferrite core to shocks will cause it to break or crack, rendering it unusable.

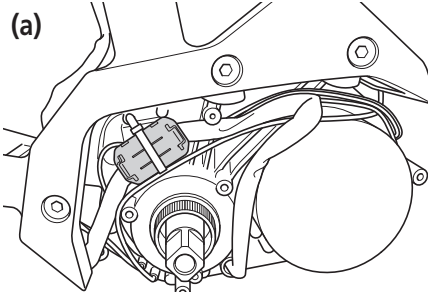
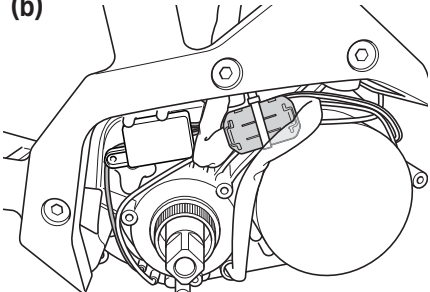
3	<p>Position the ferrite core so that the power cord fits inside the drive unit.</p> <p>(a) For SM-BME60 (b) For SM-BME61</p>	 
---	--	--

▶▶ Connecting the electric wire

■ Connecting the electric wire

1

Set so that the projection on the connector is aligned with the groove on the narrow end.

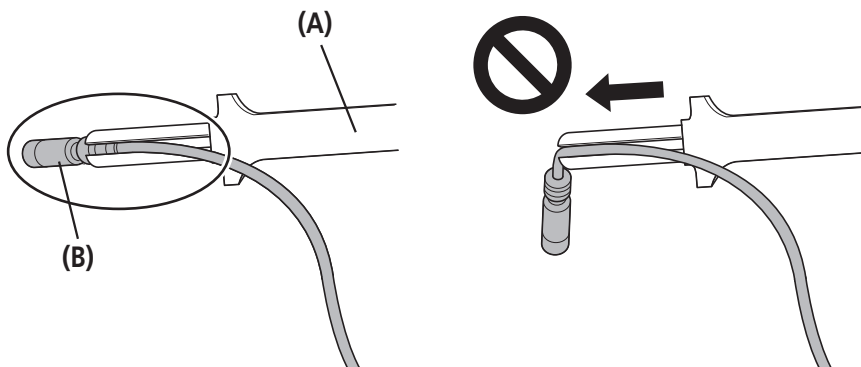
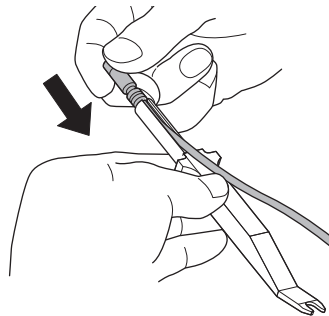

- (A) TL-EW02
- (B) Plug

**NOTE**

Use the Shimano original tool for installation and removal of the electric wire. When installing the electric wire, do not forcibly bend the plug. It may result in a poor contact. When connecting the electric wire, push it in until it clicks in place.

■ Connecting the assist switch and drive unit to the cycle computer

Use the TL-EW02 (D) for connection.

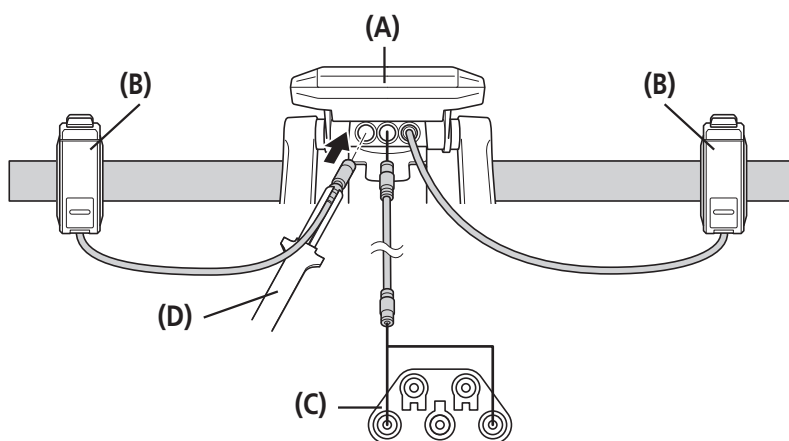

- (A) Cycle computer
- (B) Assist/Shift switch
- (C) Drive Unit
- (D) TL-EW02

 **TECH TIPS**

The electric wire connector can be connected to any port of the cycle computer, but we recommend you connect the assist switch to the switch-side port.

## ■ Connecting the speed sensor to the drive unit

Connect the speed sensor unit electric wire to the drive unit speed sensor connector (B) using the TL-EW02 (A).

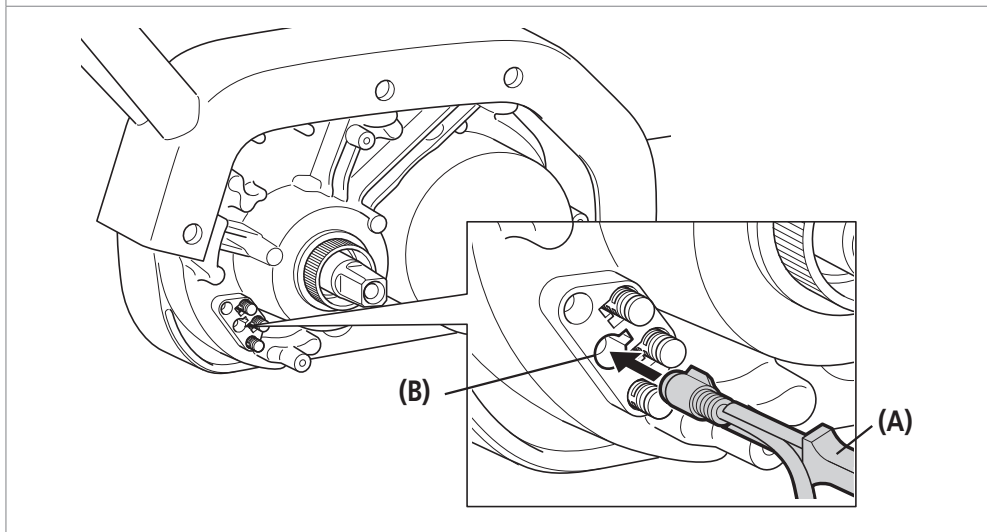

(A) TL-EW02

(B) Speed sensor connector

## ■ Connecting the light adapter to the drive unit

To connect the light using the light adapter, carry out wiring as follows.

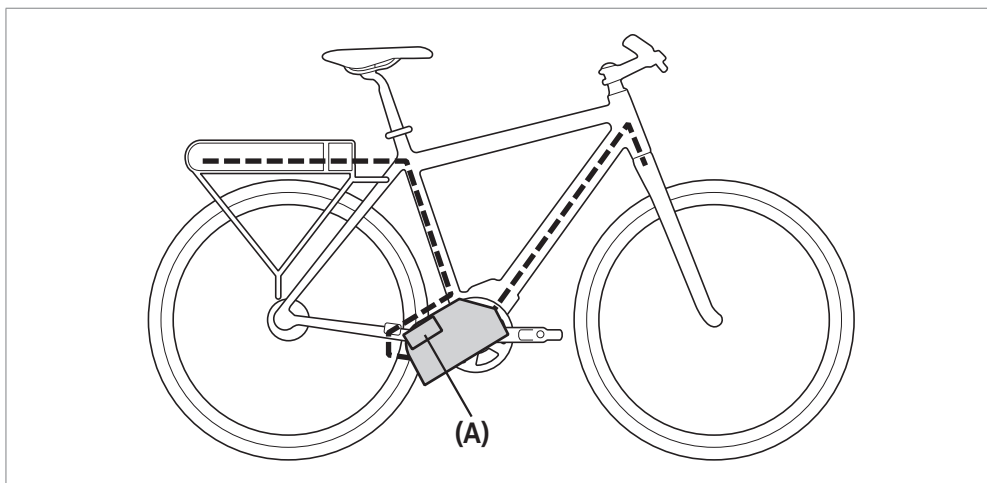

(A) Light adapter

**1** Attach the light adapter (A) in the direction shown in the illustration. Secure it to the drive unit with the unit fixing screw (B).

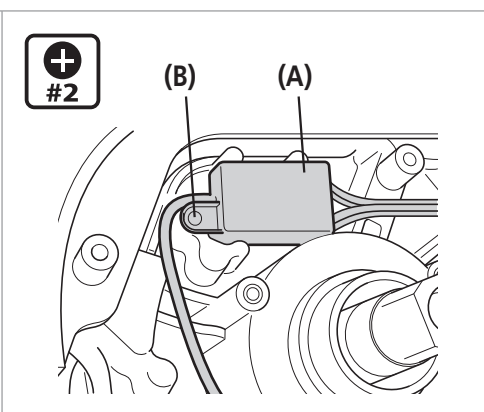

(A) Light adapter

(B) Unit fixing screw

(B)  Tightening torque:  
0.6 N·m

## INSTALLING AND WIRING THE DRIVE UNIT

### ▶▶ Connecting the light adapter to the drive unit

2

Remove the dummy plug (C) from the drive unit with TL-EW02.

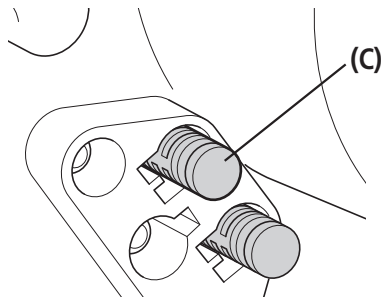

(C) Dummy plug

3

Attach the connector of the light adapter to the drive unit.

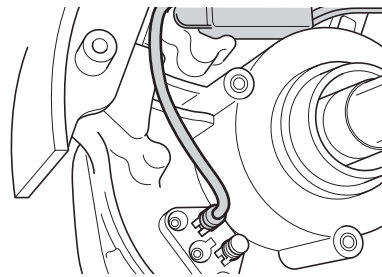

4

Pass the front light and tail light cables through the cable holes (D) and attach the cover.  
Tighten the cover fixing bolts (E) in the three locations.

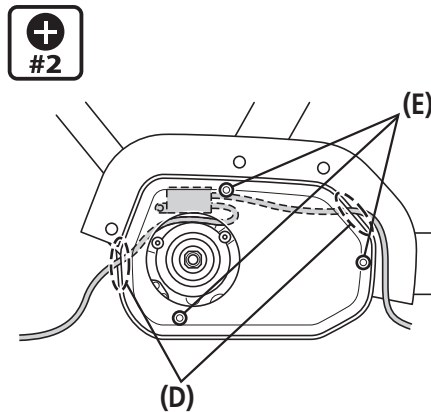

(D) Cable holes

(E) Cover fixing bolt (M3)

(E)  Tightening torque:  
0.6 N·m

5

Fix the light cables to the electric wire around the light adapter and route them along the frame.

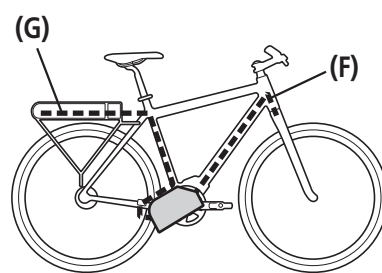

(F) Front light cable

(G) Taillight cable



**TECH TIPS**

For information on compatible lights, contact a manufacturer of completed bicycles.

▶▶ Installing the ferrite core (MU-S705)

**■ Installing the ferrite core (MU-S705)**

If a ferrite core is included with MU-S705, install it by following the procedure described below.

Depending on the specifications, a ferrite core may not be included with MU-S705, so installation is not required.

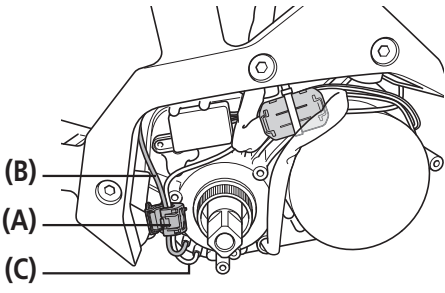
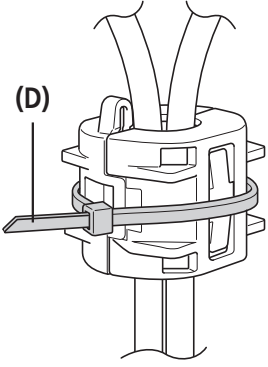
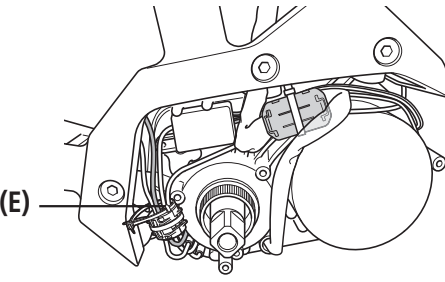
<p><b>1</b></p>	<p>Install the ferrite core <b>(A)</b> onto electric wire for motor unit <b>(B)</b> and electric wire for cycle computer <b>(C)</b>.</p>		<p><b>(A)</b> Ferrite core  <b>(B)</b> Electric wire (EW-SD50) for motor unit  <b>(C)</b> Electric wire (EW-SD50) for cycle computer</p>
<p><b>2</b></p>	<p>Make sure that the electric wires are not pinched and firmly secure the ferrite core. Then, fix the ferrite core with the zip tie <b>(D)</b>. The zip ties are included with MU-S705.</p>		<p><b>(D)</b> Zip tie</p> <hr/> <p style="text-align: center;"><b>NOTE</b></p> <ul style="list-style-type: none"> <li>• Check that the ferrite core tabs are firmly secured.</li> <li>• Do not cut off the excess portion of the zip tie. The cut surface of the zip tie may scratch the cable or case.</li> <li>• Do not drop the ferrite core or subject it to any shocks. Subjecting the ferrite core to shocks will cause it to break or crack, rendering it unusable.</li> </ul>
<p><b>3</b></p>	<p>Pass the zip tie through projection <b>(E)</b> located at the top of the ferrite core. Bundle together the electric wires and peripheral wires, and fix them with the zip tie.</p>		<p><b>(E)</b> Projection</p>

## ■ Installing the crank and front chainring

Perform the procedure below for all models, regardless of whether with powered or mechanical gear shifting.

**1**

Install the left crank arm.  
Align the round indentation (A) on the square spindle with the installation direction of the crank arm (B) as shown in the illustration.

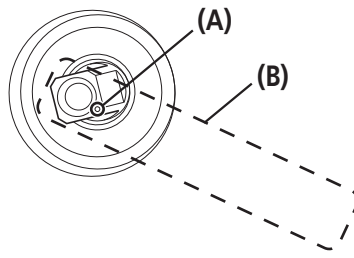

- (A) Indentation
- (B) Installation direction of the crank arm

**2**

Attach the crank arm fixing bolt and tighten it with a 14 mm socket wrench (C).

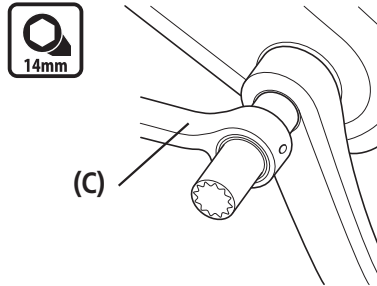

- (C) 14 mm socket wrench

(C)  **Tightening torque:**  
35 - 50 N·m

**3**

Align the cutout in the front chainring (D) with the wide area (F) on the chainring installation part (E) when inserting the front chainring.

<In the case of DU-E6000>

- When installing a front chainring labeled "SM-CRE60", a spacer needs to be placed between the front chainring and the chainring installation part. In this case, consult an agency.

<For the DU-E6001/E6010/E6050>

- This can be attached only on front chainrings labeled "SM-CRE60".
- There are also models without a wide area. For those models, positioning is not needed to install the front chainring.

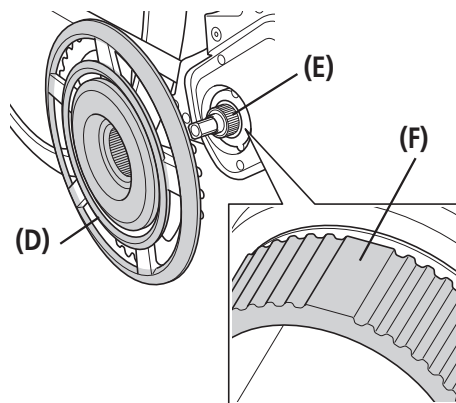

- (D) Front chainrings
- (E) Chainring installation part
- (F) Wide part

## INSTALLING AND WIRING THE DRIVE UNIT

### ▶▶ Installing the crank and front chainring

4

Tighten the lock ring by hand and attach the Shimano original tool.  
While holding the left crank, tighten the lock ring in the direction shown in the illustration.

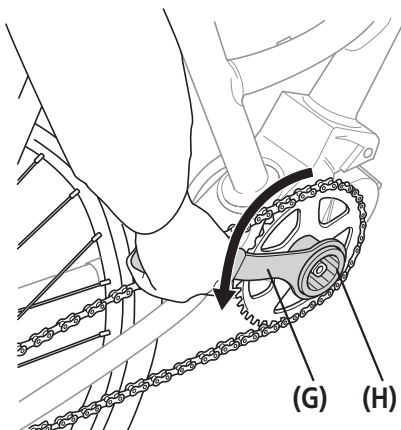

(G) TL-FC32 / FC36

(H) TL-FC38

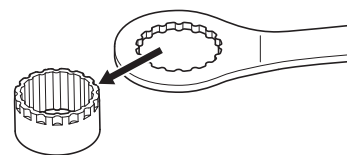

TL-FC38

#### NOTE

If using a torque wrench, use TL-FC38 in combination with TL-FC33.



TL-FC38

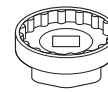

TL-FC33

\* An impact wrench cannot be used.



#### TECH TIPS

The lock ring has a left hand thread.



Tightening torque:  
35 - 45 N·m



Tightening torque:  
35 - 50 N·m

5

Insert the right crank arm attach the crank arm fixing bolt, and tighten it.  
Finally, attach the crank arm cap.

6

After installing the crank arm, rotate the crank to check that it rotates smoothly.

## ■ Measuring and adjusting the chain tension

When using an internal geared hub, it is necessary to adjust the chain tension.

### Measure and adjust the chain tension manually.

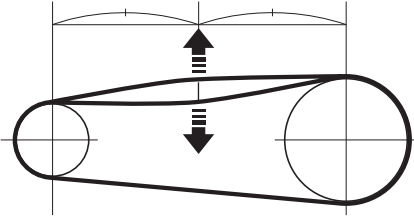
1	Set the chain in place and pull it up and down with a force of about 10N (1kg).	
---	---	--



2	Adjust so that there is 15 mm or more of slack in the chain.
---	--

### Measure and adjust chain tension with the chain tension measurement tool (TL-DUE60).

Set the chain in place, then apply pressure from the top or bottom of the chain with the chain tension measurement tool.

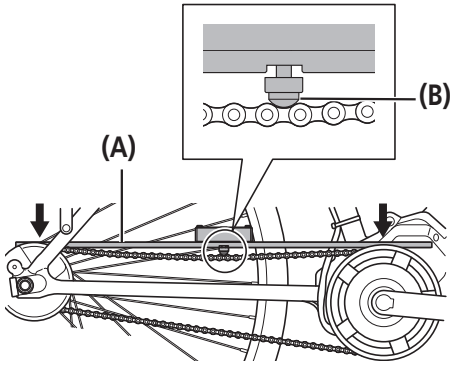
#### When measuring and adjusting the chain tension from the top of the chain:

1	Place the chain tension measurement tool (A) against the top of the chain and press down until it touches the front chainring and rear sprocket.		<p><b>(A)</b> Chain tension measurement tool (TL-DUE60)</p> <p><b>(B)</b> Projection part</p>
---	--	---	---

2	Adjust the chain tension so that the projection part (B) does not stick out at all from the chain tension measurement tool's frame section.	<div style="display: flex; align-items: center;"> <div style="margin-right: 10px;"></div> <div>Projection part not sticking out beyond tool's frame</div> </div> <div style="display: flex; align-items: center; margin-top: 10px;"> <div style="margin-right: 10px;"></div> <div>Projection part sticking out beyond tool's frame</div> </div>
---	---	---



**When measuring and adjusting the chain tension from the bottom of the chain:**

**1**

Place the chain tension measurement tool (A) against the bottom of the chain and press up until it touches the front chainring and rear sprocket.

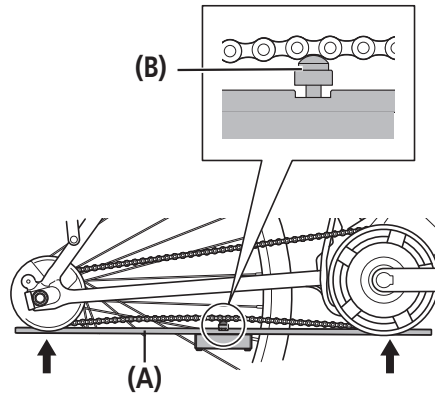

**(A)** Chain tension measurement tool (TL-DUE60)

**(B)** Projection part

**2**

Adjust the chain tension so that part C of the projection part (B) is not hidden by the chain tension measurement tool's frame.

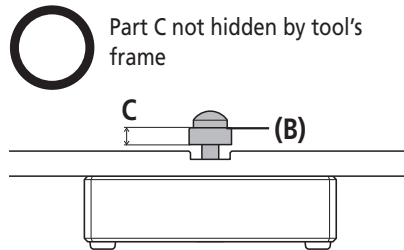

Part C not hidden by tool's frame

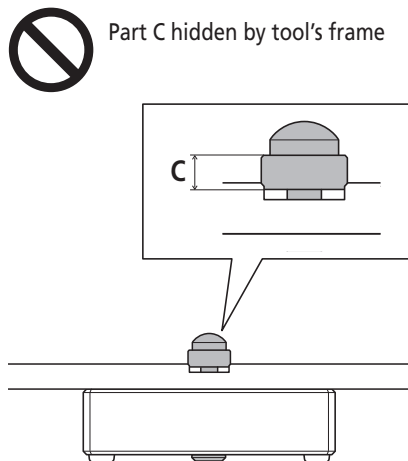

Part C hidden by tool's frame

# CHARGING THE BATTERY

# CHARGING THE BATTERY

## ■ Introduction

The battery cannot be used immediately after purchase as it will be in deep sleep mode. Charging the battery with the dedicated battery charger will release the battery from deep sleep mode, allowing the battery to be used. The battery can be used when the LED on it turns on. The battery can also be released from deep sleep mode by connecting to E-TUBE PROJECT when the bicycle is fitted with all components.

## ■ Proper use of the battery

Charging can be carried out at any time regardless of the amount of charge remaining, but you should fully charge the battery in the following cases. Be sure to use the dedicated charger to charge the battery.

- The battery is uncharged at the time of shipment. Before riding, be sure to charge the battery until it is fully charged.

If the battery has become completely discharged, charge it as soon as possible. If you leave the battery uncharged, the battery may deteriorate.

- If the bicycle will not be ridden for a long period of time, store it away with approximately 70% battery capacity remaining. In addition, take care not to let the battery become completely empty by charging it every 6 months.
- Do not connect to E-TUBE PROJECT while the battery is being charged.

The use of a genuine Shimano battery is recommended. If using a battery from another manufacturer, make sure to carefully read the instruction manual for the battery before use.

- Connect to E-TUBE PROJECT and click [Connection check] to confirm whether the battery in use is a genuine Shimano battery or another brand.

## ■ Charging procedures

### When charging the battery alone

<EC-E6000>/<BT-E6000/BT-E6001/BT-E6010>

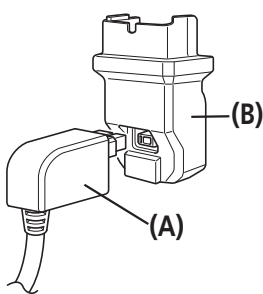
<b>1</b>	Attach the adapter (B) to the battery charger's charging plug (A).	
----------	--	---

- 
- (A) Charging plug
  - (B) Adapter
- 

<b>2</b>	Connect the battery charger's power plug to the outlet.
----------	---

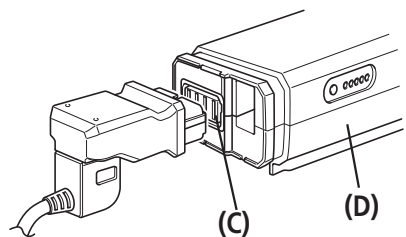
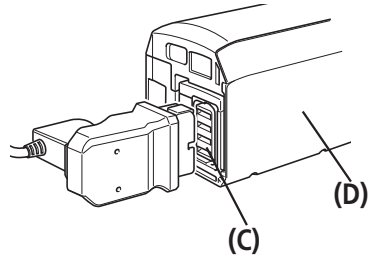
<b>3</b>	<p>Insert adapter (B) into the battery's charging port (C).</p> <p>* When inserting the adapter into the charging port, insert it so that the charging plug is positioned below the adapter. The adapter cannot be inserted if the charging plug is above the adapter.</p> <p>* Charge the battery on a flat surface indoors.</p>	<p>&lt;BT-E6000/BT-E6001&gt;</p>  <p>&lt;BT-E6010&gt;</p> 
----------	---	--

- 
- (C) Charging port
  - (D) Battery
-

## CHARGING THE BATTERY

### ▶▶ Charging procedures

#### <EC-E6000>/<BT-E8010/BT-E8020>

- 1 Connect the battery charger's power plug to the outlet.

Insert the charging plug (A) into the battery's charging port (B).

<BT-E8010>

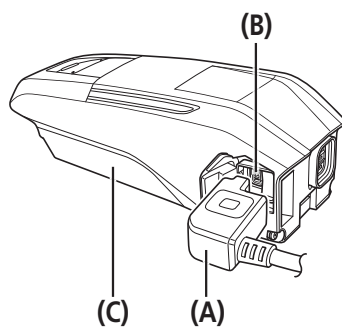

<BT-E8020>

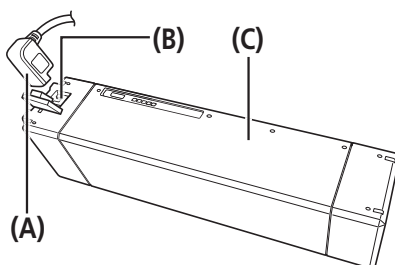

- (A) Charging plug
- (B) Charging port
- (C) Battery

#### NOTE

Charge the battery on a flat surface indoors.

## 2

#### <SM-BCE60>/<BT-E6000/BT-E6001/BT-E6010>

Attach the charger plug to the charging port (B) of the battery (A). Insert it with the groove (C) side of the plug facing the direction shown in the illustration.

<BT-E6000/BT-E6001>

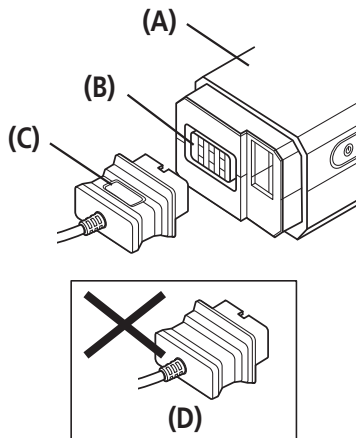

<BT-E6010>

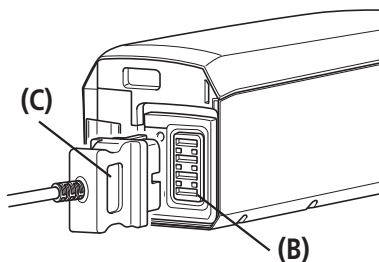

- (A) Battery
- (B) Charging port
- (C) Groove
- (D) Back side (No groove)

**When charging the battery while it is mounted on the bicycle**

<EC-E6000>/<BT-E6000/BT-E6001/BT-E6010/BT-E8010/BT-E8020>

**1** Connect the charger's power plug to the outlet.

Insert the charging plug (C) into the charging port (B) on the battery mount (A) or the battery (D).

- \* Place the battery charger on a steady surface such as the floor before charging.
- \* Stabilize the bicycle to ensure that it does not collapse during charging.

- (A)** Battery mount
- (B)** Charging port
- (C)** Charging plug
- (D)** Battery

**2**

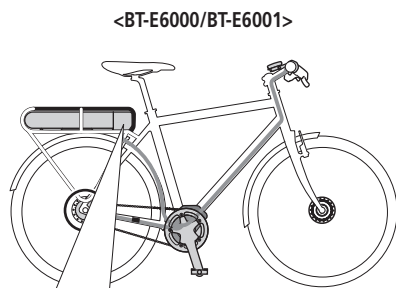

<BT-E6000/BT-E6001>

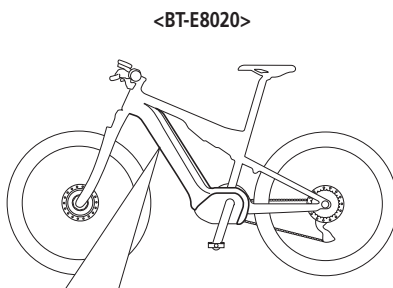

<BT-E8020>

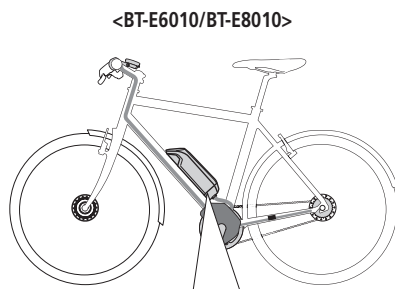
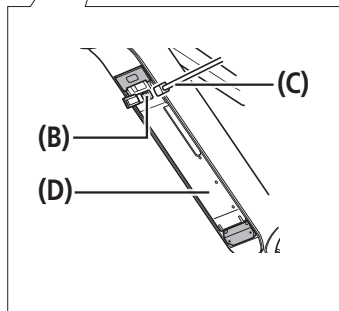
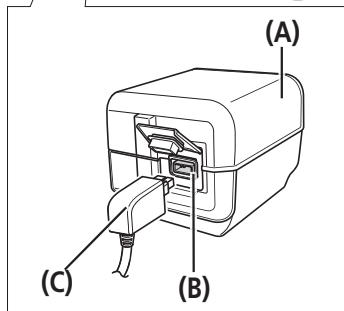

<BT-E6010/BT-E8010>

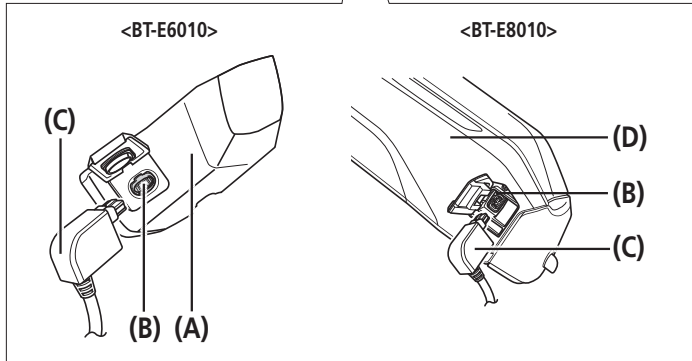

<BT-E6010>

<BT-E8010>

## CHARGING THE BATTERY

### ▶▶ About the charger LED lamp

#### ■ About the charger LED lamp

After charging has started, the LED lamp (A) on the charger lights up.

● Lit up	Charging (Within 1 hour after the completion of charging)
☀ Blinking	Charging error
● Turned off	Battery disconnected (1 hour or more after the completion of charging)

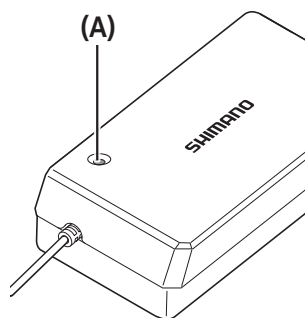

(A) Charger LED lamp

#### **! DANGER**

Use the battery and charger combination specified by the company for charging and follow the charging conditions specified by the company. Not doing so may cause overheating, bursting, or ignition of the battery.

#### **NOTE**

If the bicycle is stored for an extended period of time immediately after purchase, you will need to charge the battery before using the bicycle. Once the battery is charged, it starts to deteriorate slightly.

#### ■ About the battery LED lamps

You can check the current charging status on the battery level lamp (A) located on the battery.

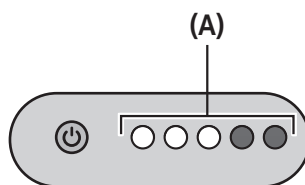

(A) Battery LED lamp

### Charging-in-progress indication

Battery level indication*1	Battery level
☀ ● ● ● ●	0% - 20%
○ ☀ ● ● ●	21% - 40%
○ ○ ☀ ● ●	41% - 60%
○ ○ ○ ☀ ●	61% - 80%
○ ○ ○ ○ ☀	81% - 99%
○ ○ ○ ○ ○	100%

\*1 ●: Not lit ○: Lit up ☀: Blinking

## Battery level indication

The current battery level can be checked by pressing the battery's power button.

Battery level indication*1	Battery level
○ ○ ○ ○ ○	100% - 81%
○ ○ ○ ○ ●	80% - 61%
○ ○ ○ ● ●	60% - 41%
○ ○ ● ● ●	40% - 21%
○ ● ● ● ●	20% - 1%
☀ ● ● ● ●	0% (When battery is not installed on bicycle)
● ● ● ● ●	0% (When battery is installed on bicycle) Power off / Shutdown

\*1 ●: Not lit ○: Lit up ☀: Blinking

## Error indication

System errors and similar warnings are indicated by the battery LED lamps through various lighting patterns.

Error indication type	Indication condition	Lighting pattern *1	Recovery
System error	Communication error with the bicycle system	☀ ● ● ● ○	Make sure that the cable is not loose or improperly connected. If the situation does not improve, contact an agency.
Temperature protection	If the temperature exceeds the guaranteed operating range, the battery output is turned off.	☀ ● ● ○ ●	Leave the battery in a cool place away from direct sunlight until the internal temperature of the battery decreases sufficiently. If the situation does not improve, contact an agency.
Security authentication error	This is displayed if a genuine drive unit is not connected. This is displayed if any of the cables are disconnected.	☀ ● ○ ● ●	Connect a genuine battery and drive unit. Check the condition of the cables. If the situation does not improve, contact an agency.
Charging error	This is displayed if an error occurs during charging.	☀ ○ ● ● ●	Remove the connector between the battery and charger, and press the power switch with only the battery connected. If an error appears with only the battery connected, contact an agency.
Battery malfunction	Electrical failure inside the battery	☀ ● ● ● ☀	Connect the charger to the battery and then remove the charger. Press the power switch with only the battery connected. If an error appears with only the battery connected, contact an agency.

\*1 ●: Not lit ○: Lit up ☀: Blinking

## ■ Turning the power ON / OFF

### Automatic power off function

If the bicycle has not moved for over 10 minutes, the power will automatically turn off.

### Turning the power ON and OFF via the cycle computer

Hold down the power button (A) on the cycle computer for 2 seconds.

<SC-E6010>

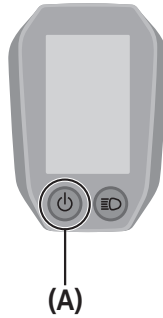

(A) Power button

#### NOTE

If built-in battery of cycle computer isn't charged sufficiently, the power will not turn on.  
The built-in battery of the cycle computer is charged only when the cycle computer screen is on.

### Turning the power ON and OFF via the battery

Press the power button (A) on the battery.

The LED lamps will light up indicating remaining battery capacity.

<BT-E6000/BT-E6001>

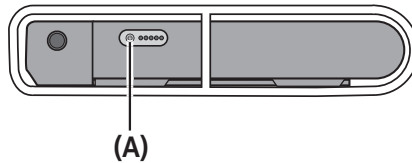

<BT-E6010>

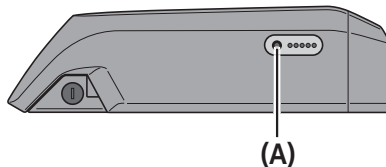

<BT-E8010>

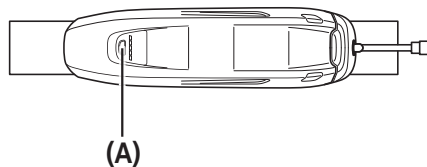

<BT-E8020>

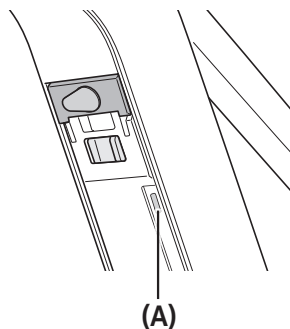

(A) Power button

#### NOTE

- When turning on the power, check that the battery is firmly attached to the holder.
- Power cannot be turned on while charging.
- Do not place your foot on the pedals when turning on. A system error may result.

#### TECH TIPS

BT-E8010/BT-E8020 can be forced to power off by holding down the power button for 6 seconds.



# **CYCLE COMPUTER DISPLAY AND SETTING**

## CYCLE COMPUTER DISPLAY AND SETTING

The following explains the operation procedure for cases where the switch settings are set to the default values.

### ■ Names and functions of the parts of the assist switch

X	Changing the cycle computer display
Y	When switching assist modes: the level of assistance becomes stronger
	When shifting gears: pedaling becomes heavier
Z	When switching assist modes: the level of assistance becomes weaker
	When shifting gears: pedaling becomes lighter

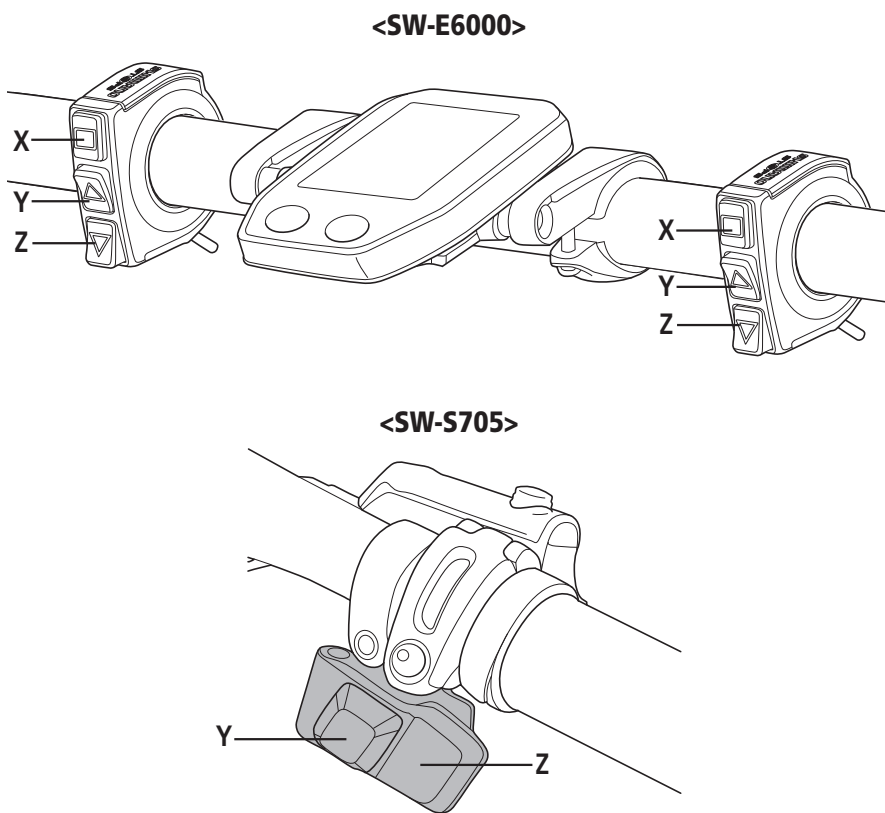

■ Basic screen display of the cycle computer

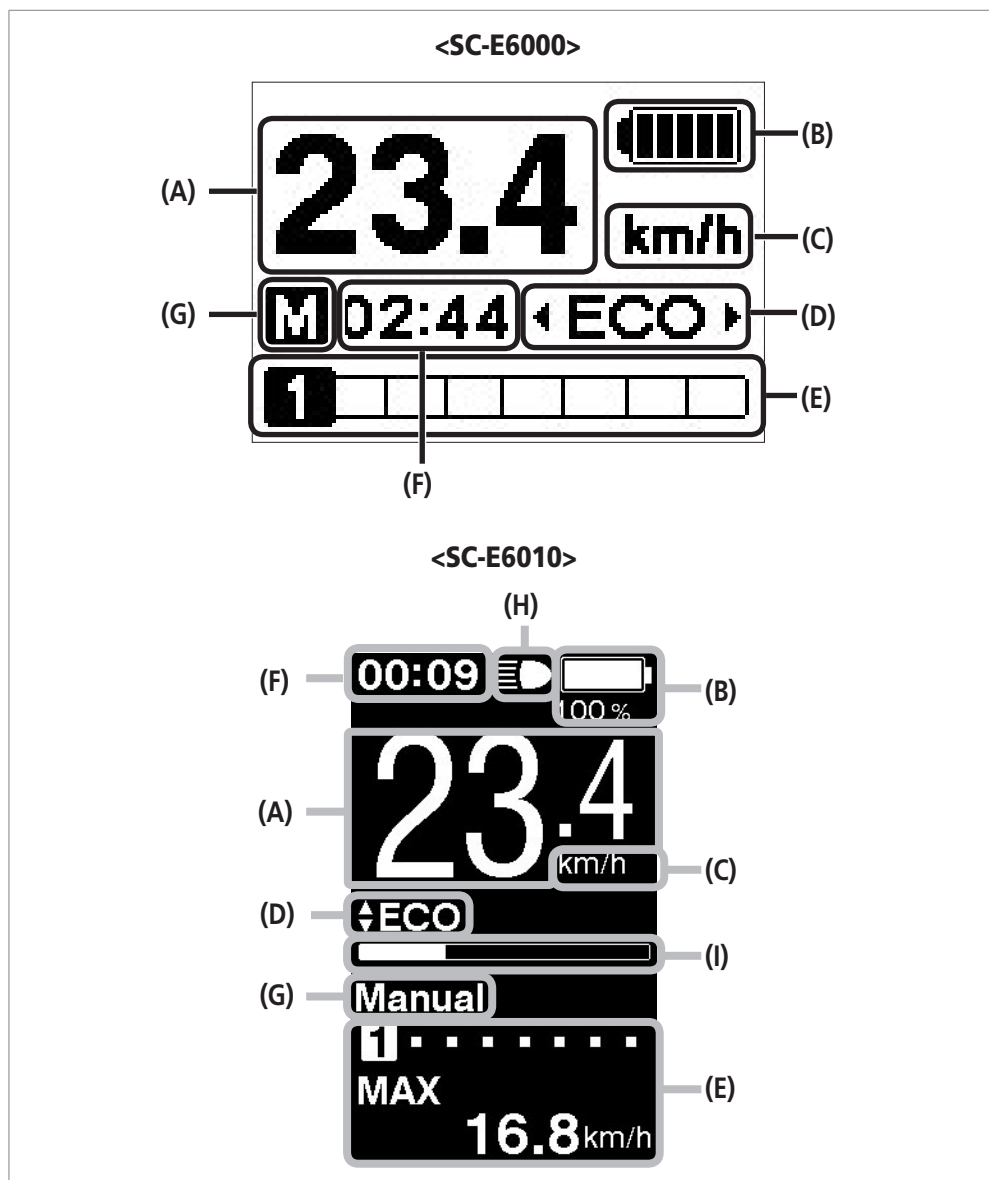







- (A) Current speed**  
Displays the current speed.
- (B) Battery level indicator**  
Displays the current battery level.
- (C) Speed unit display**  
The display can be switched between km/h and mph.
- (D) Assist mode**  
Displays the current assist mode.
- (E) Gear position and traveling data display**  
Displays the currently set gear position or the traveling data. Operate the assist switch to change the display for SC-E6000 from the gear position display to the traveling data display.
- (F) Current time**  
Displays the current time.
- (G) Gear shifting mode**  
The current gear shifting mode is displayed as following.  
SC-E6000: [A] (Auto)/[M] (Manual)  
SC-E6010: [Auto]/[Manual]
- (H) Light icon**  
Indicates that the battery-powered light is on.
- (I) Assist gauge**  
Displays the assistance.





**B**

You can check the battery level on the cycle computer while riding.

**<SC-E6000>**

Display	Battery level
	81 - 100%
	61 - 80%
	41 - 60%
	21 - 40%
	1 - 20%
	0%

**<SC-E6010>**

Display	Battery level
	100%
	
	0%

**(B) Battery level indicator**



**TECH TIPS**

When the traveling data display (E) is set to [RANGE], the battery level is not displayed.

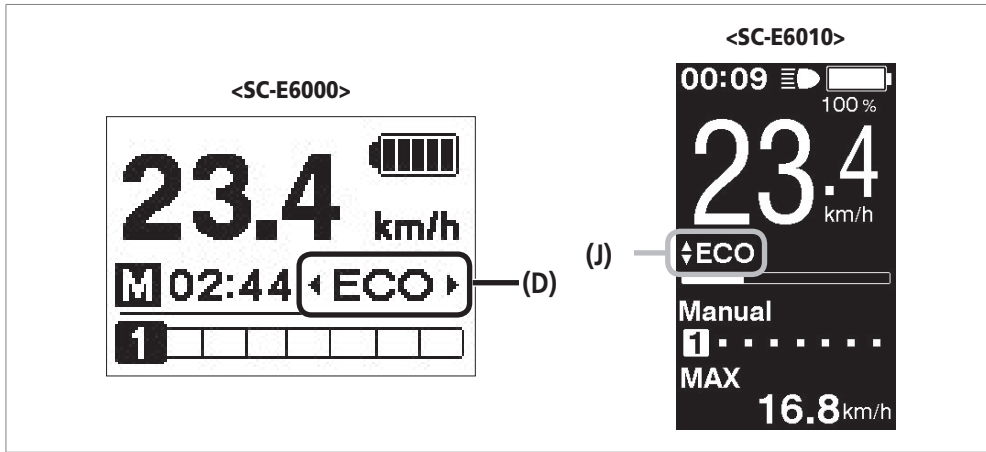

(D) (J) Changing the assist mode display

**Assist**

X X

Y Y

Z Z

**Shift**

X X

Y Y

Z Z

↑ Assist-Y

↓ Assist-Z

HIGH

△ ▽

NORM

△ ▽

ECO

△ ▽

OFF

△ ▽

Long press for 2 seconds

WALK

Displays the current assist mode. Press Assist-Y or Assist-Z on the assist switch to switch assist modes.

**Assist**

X X

Y Y

Z Z

**Shift**

X X

Y Y

Z Z

2 seconds

**< Walk assist mode >**

When the speed indicator is "0", pressing the Assist-Z button for 2 seconds switches to the walk assist mode. Press Assist-Y to switch the mode to [OFF].

<SC-E6000>

0.0 km/h

02:44

OFF

↕

0.0 km/h

02:44

WALK

**Assist**

X X

Y Y

Z Z

**Shift**

X X

Y Y

Z Z

Long press

When [WALK] is displayed, press and hold down Assist-Z on the assist switch to start the walk assist function. Assist-Z stops the walk assist function, or pressing Assist-Y can stop the walk assist function.

<SC-E6010>

00:09 100%

23.4 km/h

OFF

Manual 1

MAX 16.8 km/h

↕

00:00 100%

23.4 km/h

WALK

Manual 1

MAX 16.8 km/h

**NOTE**

When [WALK] is displayed, the mode changes to [OFF] if Assist-Z on the assist switch is not operated for 1 minute or longer.

**TECH TIPS**

- If the bicycle does not move after the walk assist function turns on, the function automatically stops. To restart the walk assist function, release the assist switch and press and hold down Assist-Z again.
- The walk assist function can operate at a maximum of 6 km/h.
- The assistance level and speed vary with the gear position.

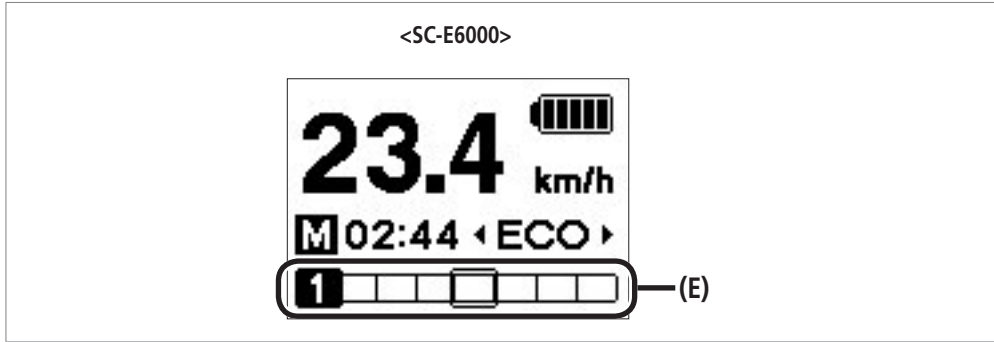

(E) Gear position and traveling data display

**Assist**      **Shift**

X X  
 Y Y  
 Z Z

Displays the sprocket position or traveling data.  
 The type of traveling data displayed changes each time you tap Assist-X.

6 ▶

◀ MAX 16.8 km/h ▶      ▶ DST 109.7 km ▶  
 ▶ ODO 11097 km ▶

◀ AVG 16.8 km/h ▶      ▶ RANGE 107 km ▶

◀ TIME 143:29 ▶

RANGE	
HIGH	61 km
NORM	77 km
ECO	97 km

Display	Details								
6	Gear *5 (displayed only when motor unit is connected.)								
1	Start gear *4 (when setting start mode)								
▶ DST 109.7 km ▶	Traveling distance								
▶ ODO 11097 km ▶	Cumulative distance								
▶ RANGE 107 km ▶	Maximum traveling distance*1, 3								
<table border="1"> <tr><th colspan="2">RANGE</th></tr> <tr><td>HIGH</td><td>61 km</td></tr> <tr><td>NORM</td><td>77 km</td></tr> <tr><td>ECO</td><td>97 km</td></tr> </table>	RANGE		HIGH	61 km	NORM	77 km	ECO	97 km	Maximum traveling distance (optional)*2
RANGE									
HIGH	61 km								
NORM	77 km								
ECO	97 km								
▶ TIME 143:29 ▶	Traveling time (optional)*2								
▶ AVG 16.8 km/h ▶	Average speed (optional)*2								
▶ MAX 16.8 km/h ▶	Maximum speed (optional)*2								

**TECH TIPS**

- \*1 When [RANGE] is displayed, the battery level and walk assist mode are not displayed. The traveling range should be used as a reference only.
- \*2 Optional item: You can configure the display settings in E-TUBE PROJECT. For details, refer to "Connection and communication with the PC"-"Settings customizable in E-TUBE PROJECT".
- \*3 When walk assistance is functioning, the on screen display [RANGE] changes to [RANGE ---].
- \*4 When start mode is functioning, the starting gear position during automatic shifting down function use is displayed.
- \*5 The gear position is only displayed when in the powered gear shifting mode.



- (G) Gear position
- (H) Traveling data display

Assist

Shift

Displays traveling data.  
The type of traveling data displayed changes each time you tap Assist-X.

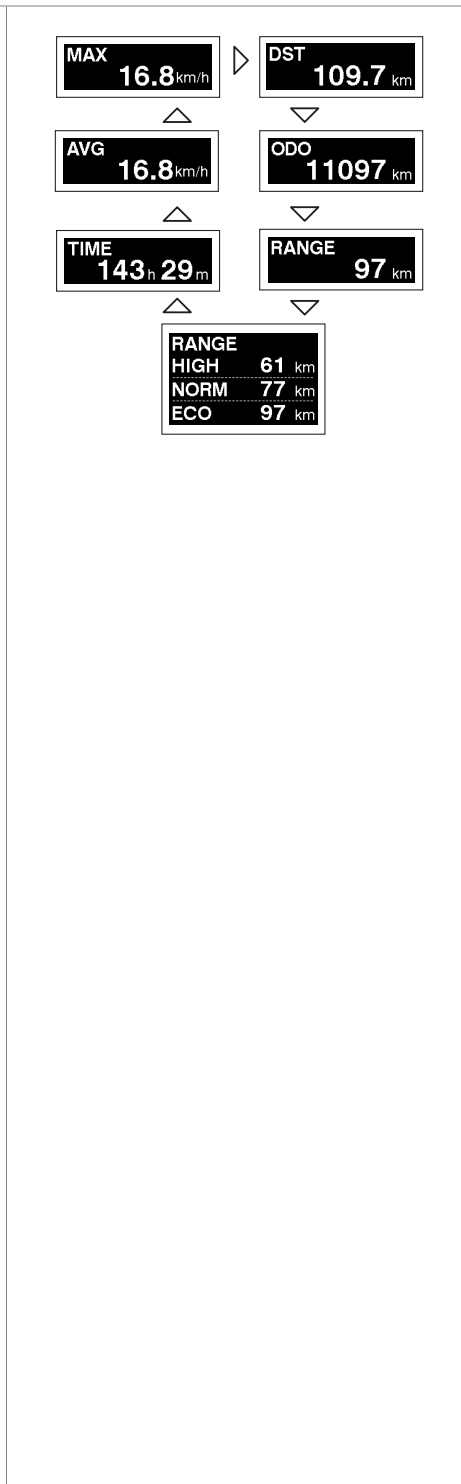







Display	Details
	Gear *5 (displayed only when motor unit is connected.)
	Start gear *4 (when setting start mode)
	Traveling distance
	Cumulative distance
	Maximum traveling distance*1, 3
	Maximum traveling distance (optional)*2
	Traveling time (optional)*2
	Average speed (optional)*2
	Maximum speed (optional)*2

**TECH TIPS**



- \*1 When [RANGE] is displayed, the battery level and walk assist mode are not displayed. The traveling range should be used as a reference only.
- \*2 Optional item: You can configure the display settings in E-TUBE PROJECT. For details, refer to "Connection and communication with the PC"- "Settings customizable in E-TUBE PROJECT".
- \*3 When walk assistance is functioning, the on screen display [RANGE] changes to [RANGE ---].
- \*4 When start mode is functioning, the starting gear position during automatic shifting down function use is displayed.
- \*5 The gear position is only displayed when in the powered gear shifting mode.

Turning the battery-powered light on or off

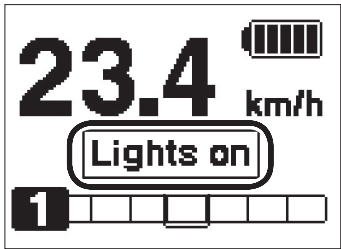
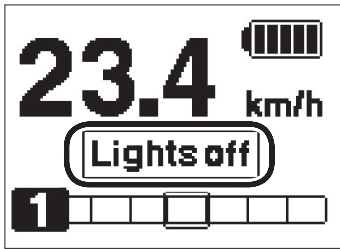
<SC-E6000>

<p><b>Assist</b>                      <b>Shift</b></p> <p>2 seconds X    X</p> <p>Y                        Y</p> <p>Z                        Z</p> <p>When the light is set in E-TUBE PROJECT, pressing the Assist-X button for 2 seconds displays the light setting information instead of the clock and assist mode. The light turns on and off each time it is displayed. It is displayed for about 2 seconds.</p>	<p>When the light is turned on</p>  <p>↔</p> <p>When the light is turned off</p> 
--	--

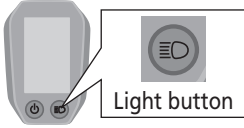
<SC-E6010>

 <p>Light button</p> <p>When a battery-powered light is connected, the light can be turned on by pressing the cycle computer's light button. When this is done, an icon indicating that the light is on appears on the screen. Press the light button again to turn the light off. The icon turns off from the display when the light is turned off.</p> <p>* When [Backlight] is set to [MANUAL] while no battery-powered light is connected, the cycle computer's backlight turns on and off each time the light button is pressed. In this case, the icon indicating that the light is on is not displayed.</p>	<p>When the light is turned on</p>  <p>↔</p> <p>When the light is turned off</p> 
---	---

 TECH TIPS

The light turns off when the battery's power is turned off.  
When the battery power is off, the light is off.



## Switching the gear shifting mode

Assist

X □  
Y ▲  
Z ▼



Shift

□ X  
▲ Y  
▼ Z

The gear shifting mode switches between auto and manual each time Shift-X is pressed with the basic screen displayed.

<SC-E6000>

Auto



Manual



<SC-E6010>

Auto



Manual



## Clearing the traveling distance

The traveling distance can be cleared in the main screen. If a battery-powered light is connected and configured, clear the traveling distance (DST) as described under "Changing the settings" - "Clear".

\* When using the SC-E6000, this function can only be used when no light is connected.

**1**

Assist

2 seconds X 

Y 

Z 



Shift

 X

 Y

 Z

Change the traveling data display to DST and press the Assist-X button for 2 seconds.

<SC-E6000>





<SC-E6010>





**2**

Assist

X 

Y 

Z 



Shift

 X

 Y

 Z

Release the button when the DST indication starts blinking.  
In this state, pressing the Assist-X button again clears the traveling distance.

<SC-E6000>



<SC-E6010>



### TECH TIPS

- If you do not operate the system for five seconds, the DST indication stops blinking and the display returns to the basic screen.
- When the traveling distance is cleared, TIME, AVG, and MAX are also cleared.

## ■ Changing the settings

### Starting the setting menu

**1**

Assist

2 seconds

Shift

With the bicycle stopped, pressing both the Assist-Y and Assist-Z buttons at the same time for 2 seconds displays the setting screen.

<SC-E6000>

<SC-E6010>

**2**

Assist

Shift

Press the Assist-Y or Assist-Z button to move the cursor to the item you want to configure.

Pressing the Assist-X button displays the setting screen for the item selected.

Settable items	Details
Clear	Clear settings
Clock	Clock setting
Start mode* <sup>2</sup>	Start mode setting
Backlight	Backlight setting
Brightness* <sup>1</sup>	Backlight brightness setting
Beep	Beep setting
Unit	Switching between km and mile
Language	Language setting
Font color* <sup>1</sup>	Font color setting
Adjust* <sup>2</sup>	Adjusting the electronic gear shifting unit
Auto* <sup>2</sup>	Adjusting the gear shifting timing
Exit	Return to the main screen



\* 1: This menu is only for the SC-E6010.



\* 2: This operation is only possible with electronic gear shifting.



# Clear

Clear the traveling distance. Or return the display setting to default.

**Assist**                      **Shift**

X                        X

Y                        Y

Z                        Z



Press the Assist-Y or Assist-Z button to move the cursor to the item you want to configure.

<SC-E6000>

14:25

**Clear**

**Exit**

**DST**                      **109.7 km**

**Default**

▼

<SC-E6010>

00:09
 100%

**Clear**

**Exit**

**DST**                      **0.0 km**

**Default**



▼



Item	Details
Exit	Return to the Setting menu screen
DST	Clearing the traveling distance
Default	Reset the SC display setting to default



Default value set in the SC display setting

Item	Default value
Backlight	ON
Beep	ON
Unit	km
Language	English
<SC-E6010> Brightness	3
<SC-E6010> Font color	White

**Assist**                      **Shift**

X                        X

Y                        Y

Z                        Z



Pressing the Assist-X button enables the set value at the cursor position and takes you back to the "Setting menu" screen.

<SC-E6000>

14:25

**Setting**

**Clear**

**Clock**

**Start mode**

**Backlight**

▼

<SC-E6010>

00:09
 100%

 **Setting**

**Clear**

**Clock**

**Start mode**

**Backlight**

**Brightness**

**Beep**

**Unit**

**Language**

▼

## TECH TIPS

When the traveling distance is cleared, TIME, AVG, and MAX are also cleared.

# Clock

Configure the clock setting.

**1**

Assist

X

Y

Z

Shift

X

Y

Z

Press the Assist-Y or Assist-Z button to adjust the time.

<SC-E6000>

<SC-E6010>

**TECH TIPS**

Press Assist-Y to increase the numbers.  
Press Assist-Z to decrease the numbers.

**2**

Assist

X

Y

Z

Shift

X

Y

Z

Pressing the Assist-X button enables the set value and moves you to the minutes setting.

<SC-E6000>

<SC-E6010>

**3** Press the Assist-Y or Assist-Z button to set the minutes.

---

**4** Pressing the Assist-X button enables the set value and takes you back to the "Setting menu" screen.

Assist

X

Y

Z

Shift

X

Y

Z

▶

Assist

X

Y

Z

Shift

X

Y

Z

**TECH TIPS**

You can change the numbers quickly by holding down the Assist-Y or Assist-Z button.

## Start mode

Set the start gear when using start mode function.

**1**

Assist

X

Y

Z

Shift

X

Y

Z

Press the Assist-Y or Assist-Z button to move the cursor to the item you want to configure.

<SC-E6000>

<SC-E6010>

**2**

Pressing the Assist-X button enables the set value at the cursor position and takes you back to the "Setting menu" screen.

Assist

X

Y

Z

Shift

X

Y

Z

Item	Details
OFF	No setting
2	2-speed
3	3-speed
4	4-speed
5	5-speed

### NOTE

When in a lower gear than the one set while stopped, the gear will not shift up automatically.

### TECH TIPS

Even with auto gear shifting enabled, when the bicycle is stopped, gear position will return to the start mode start gear that was set.

## Backlight

Configure the display backlight setting.

**1**

Assist

Shift

Press the Assist-Y or Assist-Z button to move the cursor to the item you want to configure.

<SC-E6000>

<SC-E6010>

Item	Details
ON	Keep light always on
OFF	Keep light always off
MANUAL	Turns on and off in conjunction with the battery-powered light

**2**

Pressing the Assist-X button enables the set value and takes you back to the "Setting menu" screen.

Assist

Shift

## Brightness <SC-E6010>

The brightness of the backlight can be adjusted as needed.

**1**

Assist

Shift

Press the Assist-Y or Assist-Z button to adjust the brightness.

\* The brightness can be adjusted in 5 levels.

00:09 100%

Brightness

↔

00:09 100%

Brightness

**2**

Pressing the Assist-X button enables the set value at the cursor position and takes you back to the "Setting menu" screen.

Assist

Shift

# Beep

The beep sound can be turned on/off.

**1**

Assist

X

Y

Z

Shift

X

Y

Z

Press the Assist-Y or Assist-Z button to move the cursor to the item you want to configure.

<SC-E6000>

<SC-E6010>

**2**

Pressing the Assist-X button enables the set value at the cursor position and takes you back to the "Setting menu" screen.

Assist

X

Y

Z

Shift

X

Y

Z

Item	Details
ON	Enable beeps
OFF	Disable beeps

**TECH TIPS**

Even when [Beep] is set to [OFF], a beep will sound when there is a misoperation, system error, etc.





# Unit

Distance units (km/miles) can be switched.

1

Assist

X 

Y 

Z 



Shift

X 

Y 

Z 

Press the Assist-Y or Assist-Z button to move the cursor to the item you want to configure.

<SC-E6000>



<SC-E6010>





Item	Details
km	Displayed in km
mile	Displayed in miles

2

Pressing the Assist-X button enables the set value and takes you back to the "Setting menu" screen.

Assist

X 

Y 

Z 



Shift

X 

Y 

Z 

## Language

Configure the language setting.

**1**

Assist



Shift



Press the Assist-Y or Assist-Z button to move the cursor to the item you want to configure.

<SC-E6000>



<SC-E6010>



Language
English
French
German
Dutch
Italian
Spanish

**2**

Pressing the Assist-X button enables the set value and takes you back to the "Setting menu" screen.

Assist



Shift



## Font color <SC-E6010>

The font color can be changed.

**1**

Press the Assist-Y or Assist-Z button to move the cursor to the item you want to configure.

Assist



Shift



<White>



<Black>

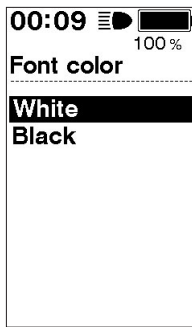

Settable items
White
Black

**2**

Pressing the Assist-X button enables the set value at the cursor position and takes you back to the "Setting menu" screen.

Assist



Shift



## Adjust

Gear shifting adjustment is performed with the electronic gear shifting unit.

### ⚠ CAUTION

- Improperly large adjustment may cause free spinning of the pedals during pedaling, resulting in an accidental fall.
- Perform adjustment only when gear shifting feels unusual. Under normal conditions, performing unnecessary adjustment may worsen gear shifting performance.

Open the Adjust screen and check whether the adjustment value is set to [0].

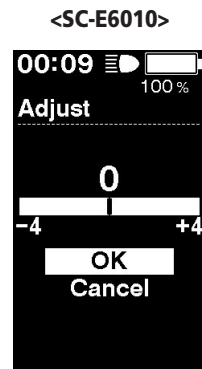
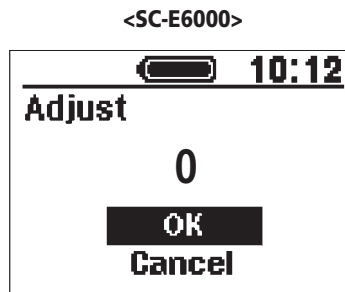

### 📖 TECH TIPS

- Gear shifting adjustment can only be performed when an electronic internal geared hub is connected.
- The settings have a range of -4 to 4.

If the adjustment value is [0]

**1**

Assist

X

Y

Z

Shift

X

Y

Z

Press Shift-Y or Shift-Z to adjust the adjustment value up or down by 1 speed.

<SC-E6000>

10:12

Adjust

-1

OK

Cancel

<SC-E6010>

00:09 100%

Adjust

-1

-4 +4

OK

Cancel

**2**

Press Assist-X.

Select [OK], then perform an actual gear shift to check whether the condition has improved.

Assist

X

Y

Z

Shift

X

Y

Z

**3**

**The condition has improved**

Adjust the adjustment value by 1 speed in the same direction and check the gear shifting operation again.

Repeat these steps until any noise or unusual feeling disappears.

<SC-E6000>

10:12

Adjust

-1

OK

Cancel

▶

<SC-E6000>

10:12

Adjust

-2

OK

Cancel

<SC-E6010>

00:09 100%

Adjust

-1

-4 +4

OK

Cancel

▶

<SC-E6010>

00:09 100%

Adjust

-2

-4 +4

OK

Cancel

3

**No apparent change**

Adjust the adjustment value by 1 speed in the same direction and check the gear shifting operation again.

If the condition has improved, see "The condition has improved" to continue.

If the condition has worsened, see "The condition has worsened" to continue.

<SC-E6000>

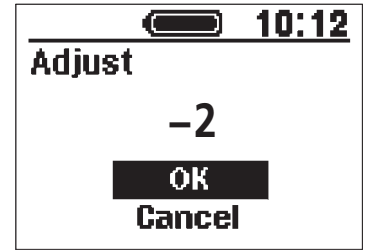
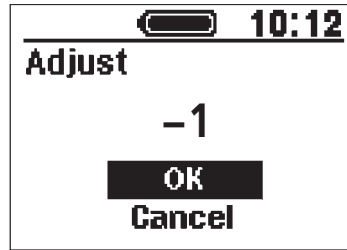

<SC-E6010>

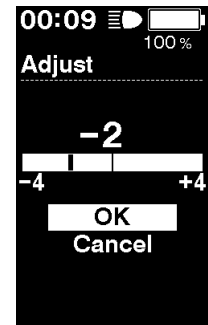
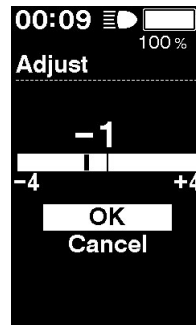

**The condition has worsened**

Adjust the adjustment value by 2 speeds in the opposite direction and check the gear shifting operation again.

Then, adjust the value by 1 speed in the same direction and check until any noise or unusual feeling is gone.

<SC-E6000>

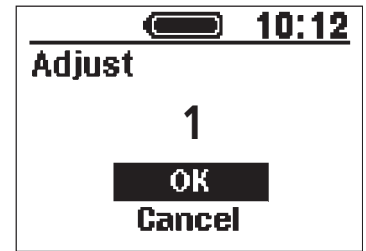

<SC-E6010>

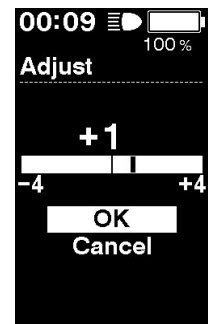
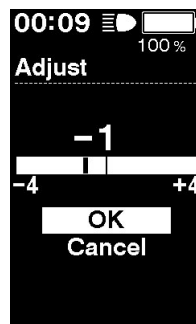

4

Finally, go for an actual ride and check for any noise or unusual feeling.

If the adjustment value is not [0]

1

Assist

X

Y

Z

Shift

X

Y

Z

Press Shift-Y or Shift-Z and revert the adjustment value to [0].

<SC-E6000>

Adjust 10:12

-4

OK

Cancel

▶

Adjust 10:12

0

OK

Cancel

<SC-E6010>

00:09 100%

Adjust

-4

-4
+4

OK

Cancel

▶

00:09 100%

Adjust

0

-4
+4

OK

Cancel

2

Press Assist-X.

Select [OK], then perform an actual gear shift to check whether the condition has improved.

If there is any noise or unusual feeling, see "If the adjustment value is [0]" to continue.

Assist

X

Y

Z

Shift

X

Y

Z

3

Finally, go for an actual ride and check for any noise or unusual feeling.

## Auto

When the gear shifting mode is set to auto, the timing at which gears shift can be adjusted.

**1**

Assist



Shift



Press Assist-Y or Assist-Z to adjust the value.

- When Assist-Y is pressed and the value is increased, the gear shifting timing is adjusted to allow for lighter pedaling.
- When Assist-Z is pressed and the value is decreased, the gear shifting timing is adjusted for heavier pedaling.

<SC-E6000>



<SC-E6010>

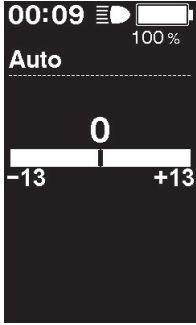

**2**

Pressing the Assist-X button sets the value you have adjusted and takes you back to the "Setting menu" screen.

Assist



Shift



### NOTE

- For SC-S705, pressing the shift up and shift down switches at the same time allows toggling between auto and manual gear shifting modes but gear shifting timing cannot be adjusted.

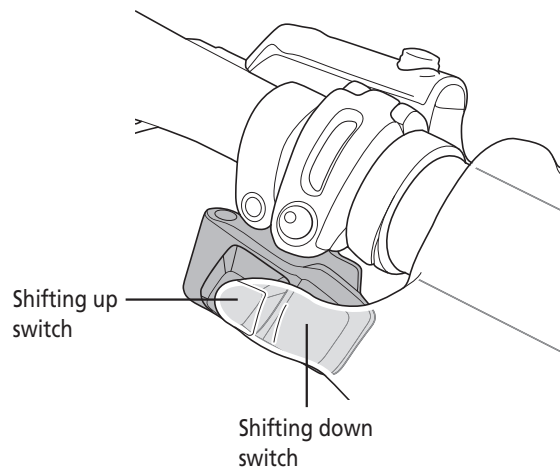

## Exit

Close the setting menu and returns to the basic screen.

**1** Press the Assist-Y or Assist-Z button to move the cursor to [Exit].

**2** Pressing the Assist-X button exits the Setting menu and takes you back to the basic screen.

### Update confirmation window for the drive unit settings backup data

The cycle computer has a function to automatically back up drive unit settings.

In the following cases, when the cycle computer power is turned on, a window confirming whether to update the backup data is displayed:

- Reinstalling the cycle computer on a bicycle with different settings
- If the drive unit settings have been changed via E-TUBE PROJECT

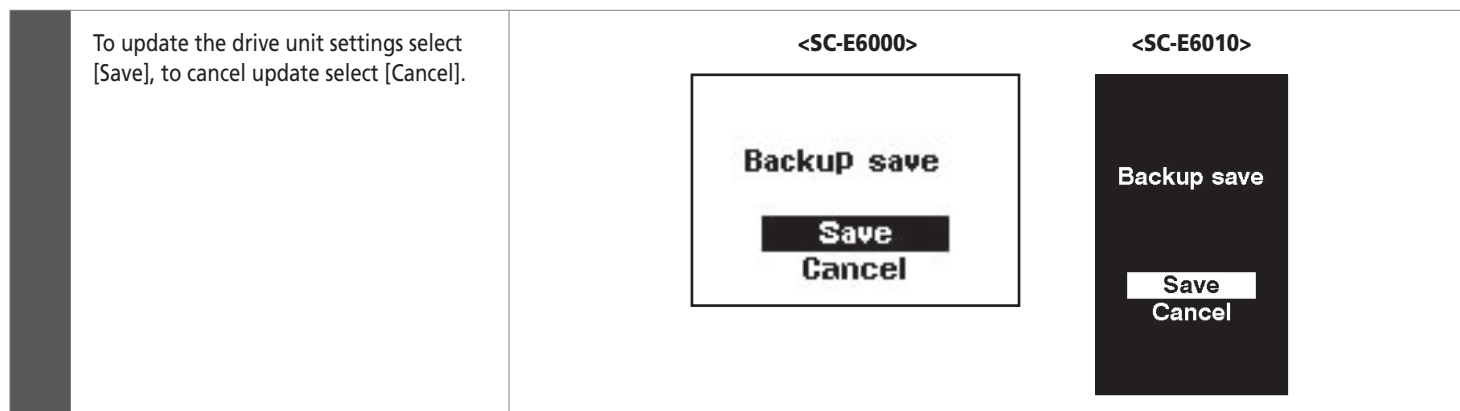

If the settings cannot be accessed due to a drive unit malfunction, they can be accessed using E-TUBE PROJECT.

## ■ Error messages on the cycle computer

### Warnings

This disappears if the error is fixed.

For the SC-E6000, a message is displayed instead of the clock.

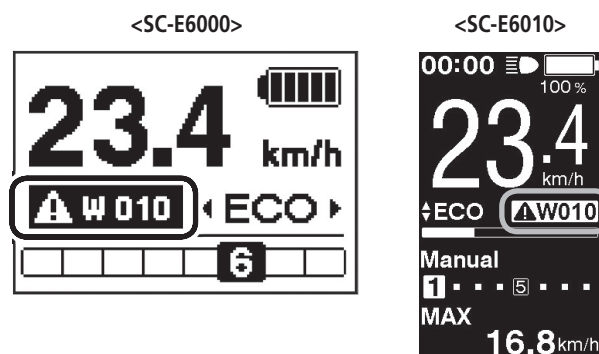

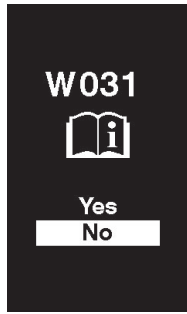
Code	Display preconditions	Operational restrictions while warning is displayed	Remedy
W031	The chain tension may not yet be adjusted or the crank may not be installed in the proper position.	The assist functions do not work. (However, electronic gear shifting will still function.)	Contact your place of purchase or a local bicycle dealer for their assistance.  <SC-E6000> 



**List of warnings**

Code	Display preconditions	Operational restrictions while warning is displayed	Remedy
W010	The temperature of the drive unit is high.	The level of assistance may decrease.	Stop using the assist function until the temperature of the drive unit drops. If the situation does not improve, consult an agency.
W011	The traveling speed cannot be detected.	The maximum speed up to which power assistance is provided may decrease. (Power assistance is provided up to 25 km/h (20 mph) in top gear.)	Check that the speed sensor is properly installed. If the situation does not improve, consult an agency.
W012	The crank may be installed in the wrong direction.	-	Re-install the crank in the specified direction, then turn the power back on.
W030	Two or more assist switches are connected to the system.	Gear shifting is not available for electronic gear shifting derailleurs.	Change the assist switch to the gear shifting switch, or connect only one assist switch and turn on the power again. If the situation does not improve, consult an agency.
-	A communication error between the drive unit and the motor unit was detected.	Gear shifting is not available for electronic gear shifting derailleurs.	Check that the cable is properly connected between the drive unit and the motor unit. If the situation does not improve, consult an agency.

**Errors**

If an error message is displayed on the entire screen, follow one of the procedures below to reset the display.

- Press the power switch of the battery.
- Remove the battery from the mount.

<SC-E6000>



<SC-E6010>



**NOTE**

If resetting does not solve the problem or the same problem occurs frequently, consult an agency.

## List of errors

Code	Display preconditions	Operational restriction when an error is being displayed	Remedy
E010	A system error was detected.	Power assistance is not provided during riding.	Press the power switch of the battery to turn on the power again. If the situation does not improve, consult an agency.
E012	The initialization of the torque sensor failed.	Power assistance is not provided during riding.	With your foot off the pedal, press the power switch of the battery to turn on the power again. Refer to "Measuring and adjusting the chain tension", then check that the chain tension is appropriate. If the situation does not improve, consult an agency.
E013	An error was detected in the drive unit's firmware.	Power assistance is not provided during riding.	Contact your place of purchase or a local bicycle dealer for assistance.
E014	The speed sensor may be installed in the wrong position.	Power assistance is not provided during riding.	Contact your place of purchase or a local bicycle dealer for assistance.
E020	A communication error between the battery and drive unit was detected.	Power assistance is not provided during riding.	Check that the cable between the drive unit and battery is properly connected. If the situation does not improve, consult an agency.
E021	Battery connected to drive unit conforms with system standards but is not supported.	Power assistance is not provided during riding.	Contact your place of purchase or a local bicycle dealer for assistance.
E022	Battery connected to drive unit does not conform with system standards.	Power assistance is not provided during riding.	Contact your place of purchase or a local bicycle dealer for assistance.
E030	A setting error was detected.	Power assistance is not provided during riding.	Press the power switch of the battery to turn on the power again. If the situation still does not improve, consult an agency.
E031	The chain tension may not yet be adjusted or the crank may not be installed in the proper position.	The assist functions do not work. (However, electronic gear shifting will still function.)	Contact your place of purchase or a local bicycle dealer for assistance.
E043	The cycle computer's firmware may be partially corrupt.	Power assistance is not provided during riding.	Contact your place of purchase or a local bicycle dealer for assistance.

# CONNECTION AND COMMUNICATION WITH PC

## CONNECTION AND COMMUNICATION WITH PC

You can connect the bicycle (system or components) to a PC via a PC linkage device to carry out tasks such as customizing single components or the whole system and updating their firmware.

You need E-TUBE PROJECT to configure SHIMANO STEPS and update firmware. Download E-TUBE PROJECT from our support website (<http://e-tubeproject.shimano.com>). For information on how to install E-TUBE PROJECT, check the E-TUBE support website. For information on how to use E-TUBE PROJECT on your PC, refer to the help manual for E-TUBE PROJECT.

### NOTE

- You need SM-PCE1 and SM-JC40/JC41 to connect SHIMANO STEPS to a PC. They are not required if there is an available port.
- Firmware is subject to change without notice.
- PC connection and communication are not possible during charging.
- Do not connect to E-TUBE PROJECT while the battery is being charged.

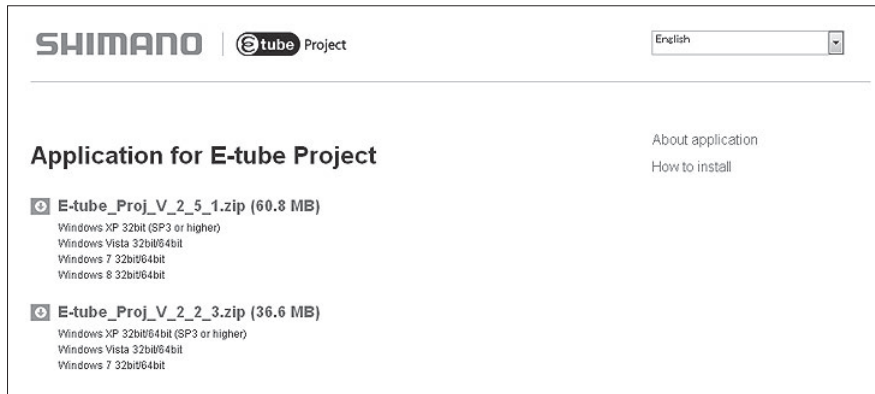

### ■ Drive unit setting backup function for the cycle computer

To check the drive unit settings backed up to the cycle computer, export the PDF report from the E-TUBE PROJECT [Unit log acquisition] menu. When exchanging the drive unit, send the report along with the unit to your place of purchase or a local bicycle dealer.

## ■ Settings customizable in E-TUBE PROJECT

<b>Switch function setting</b>		Changes the functions to assign to switches X, Y, and Z of SW-E6000 or switch X and Y of SW-S705. Functions that can be assigned vary depending on the type of switch. <ul style="list-style-type: none"> <li>• SW-E6000: The same function cannot be assigned to different switches.</li> <li>• SW-S705: The same function can be assigned to different switches.</li> </ul>
<b>Switch mode setting</b>		Sets SW-E6000 to be used for either assist mode switching or gear shifting.
<b>Drive unit setting</b>	<b>Light connection</b>	Sets whether to use a light.
	<b>Start mode</b>	Switches the start mode on or off. You can change gear position when on is selected.
	<b>Automatic gear shifting</b>	Auto gear shifting can be enabled or disabled. The timing for gear shifting can also be adjusted.
<b>Display monitor settings</b>	<b>Display units</b>	Switches the display unit between km and mile.
	<b>Time setting</b>	Sets the time.
	<b>Backlight setting</b>	Switches the backlight of the cycle computer on or off.
	<b>Backlight brightness setting (SC-E6010)</b>	The backlight's brightness can be adjusted.
	<b>Beep setting</b>	Switches the beep sound on or off.
	<b>Display language</b>	You can choose from English, French, German, Dutch, Spanish, and Italian.
	<b>Font color setting (SC-E6010)</b>	The font color can be set to white or black.
	<b>Traveling time</b>	Switches the traveling time indication on or off.
	<b>Average speed</b>	Switches the average speed indication on or off.
	<b>Maximum speed</b>	Switches the maximum speed indication on or off.
<b>Range overview</b>	Switches the traveling range list indication on or off.	
<b>Motor unit gear setting</b>		Switches MU-S705 between the 8-speed and 11-speed setting.
<b>Other functions</b>		<ul style="list-style-type: none"> <li>• Error check</li> <li>• Update firmware</li> <li>• Preset</li> <li>• Unit log acquisition</li> <li>• Customizing the motor unit (MU-S705)</li> </ul> <p>* For details, download E-TUBE PROJECT and refer to the manual provided.</p>

### NOTE

When the SC-E6010 firmware is updated, the time set for the cycle computer is reset to match the computer's clock.

## ■ Connecting to the PC

### When connecting only individual units

Connect SM-PCE1 to the connector of each unit.

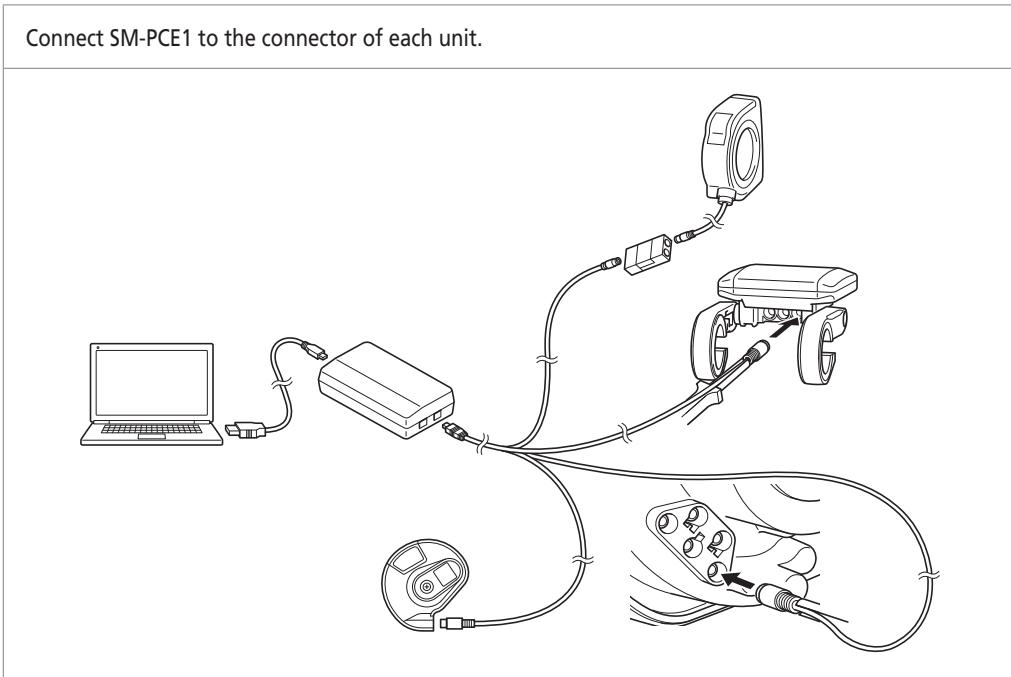

#### NOTE

When connecting only SW-E6000, you need SM-JC40/41.

Connecting to the bicycle

< When the cycle computer has an available port >

Connect SM-PCE1 to an available port of the cycle computer.

1

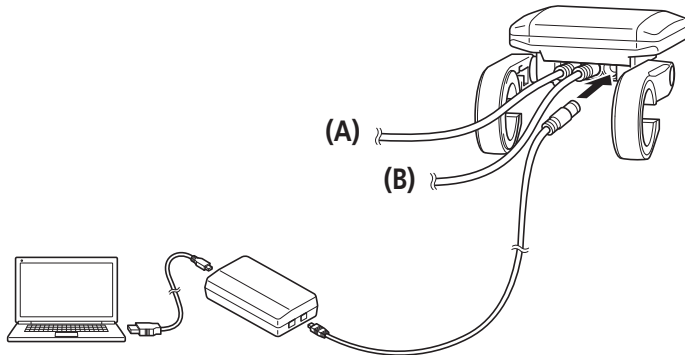

- (A) Assist switch
- (B) Drive Unit

< When the cycle computer has no available port >

First, connect SM-JC40/JC41 to SM-PCE1.  
Then, disconnect EW-SD50 from the center port of the cycle computer and connect it to SM-JC40/JC41.

1

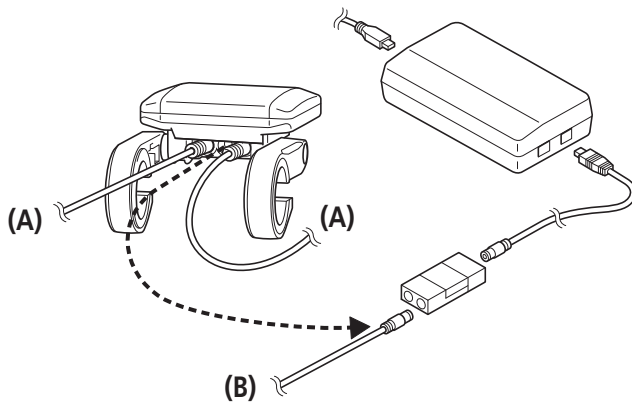

- (A) Assist switch
- (B) Drive Unit

Connect EW-SD50 to the available port of SM-JC40/JC41 and the center port of the cycle computer.

2

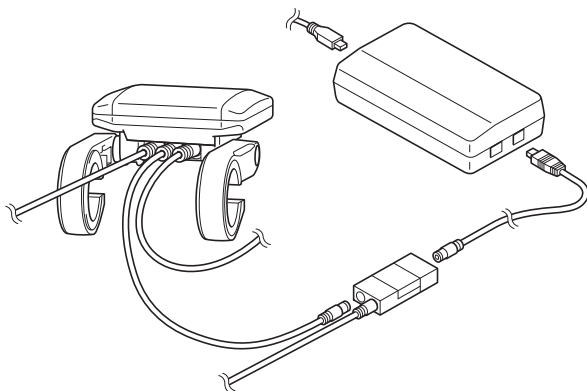

# MAINTENANCE



# MAINTENANCE

## ■ Replacing the front chainring

1

Perform replacement with the chain installed to the rear wheel. Remove the crank arm cap, then remove the crank mounting bolt with a 14 mm socket wrench. After that, remove the right side crank using TL-FC11.

2

While holding the wheel, use the Shimano original tool to loosen the lock ring in the direction shown in the illustration.

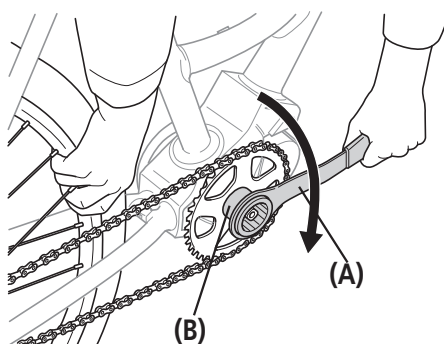

(A) TL-FC32 / FC36

(B) TL-FC38

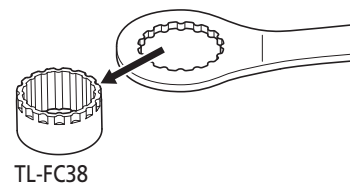

### NOTE

If using a torque wrench, use TL-FC38 in combination with TL-FC33.



TL-FC38

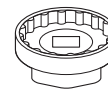

TL-FC33

\* An impact wrench cannot be used.



### TECH TIPS

The lock ring has a left hand thread.

3

Replace the front chainring. To install a front chainring refer to steps 3 to 6 in "Installing and wiring the drive unit"- "Installing the crank and front chainring".

# SHIMANO

## **SHIMANO AMERICAN CORPORATION**

One Holland, Irvine, California 92618, U.S.A. Phone: +1-949-951-5003

## **SHIMANO EUROPE B.V.**

Industrieweg 24, 8071 CT Nunspeet, The Netherlands Phone: +31-341-272222

## **SHIMANO INC.**

3-77 Oimatsu-cho, Sakai-ku, Sakai-shi, Osaka 590-8577, Japan

Please note: specifications are subject to change for improvement without notice. (English)

© Oct. 2016 by Shimano Inc. HTR