

Dealer's Manual

Shifting Lever RAPIDFIRE Plus

MTB

XTR

SL-M980-A
SL-M980-A-I
SL-M980-B-I
SM-SL98-B

SAINT

SL-M820
SL-M820-I
SL-M820-B-I
SM-SL82-B

DEORE XT

SL-M780
SL-M780-I
SL-M780-B-I
SM-SL78-B

SLX

SL-M670
SL-M670-I
SL-M670-B-I

ZEE

SL-M640

DEORE

SL-M610
SL-M610-I

ALIVIO

SL-M4000

ACERA

SL-M3000
ST-M3050

ALTUS

SL-M370
SL-M310

Trekking

DEORE XT

SL-T780

DEORE LX

SL-T670

ROAD

Tiagra

SL-4600
SL-4700
SL-4703

SORA

SL-3500
SL-3503

Claris

SL-2400
SL-2403

Non-Series

SL-R460
SL-R350
SL-R353

CONTENTS

IMPORTANT NOTICE.....	3
TO ENSURE SAFETY.....	4
INSTALLATION	5
Tools recommended.....	5
- ROAD	5
- MTB.....	5
Installation to the handlebar	6
- ROAD	6
- MTB.....	6
In the case of the I-spec system	7
Compatibility of shifting lever and brake lever	7
How to replace the normal spec system with the I-spec system	10
MAINTENANCE	11
Replacing the inner cable.....	11
- MTB / Trekking.....	11
When there is a mode converter.....	11
- MTB / Trekking / ROAD	15
When there is no mode converter.....	15
Replacement and reassembly of the indicator unit	16
- MTB / Trekking.....	16
Replacement of the indicator unit	16
Reassembly without the indicator (cover sold separately).....	17
- ROAD	21
Replacement of the shifting lever unit	23
- MTB / Trekking.....	23
- ROAD	25
Replacement of the cover.....	26
- MTB.....	26
- ROAD	26

IMPORTANT NOTICE

- **This dealer's manual is intended primarily for use by professional bicycle mechanics.**

Users who are not professionally trained for bicycle assembly should not attempt to install the components themselves using the dealer's manuals.

If any part of the information on the manual is unclear to you, do not proceed with the installation. Instead, contact your place of purchase or a local bicycle dealer for their assistance.

- Make sure to read all instruction manuals included with the product.
- Do not disassemble or modify the product other than as stated in the information contained in this dealer's manual.
- All dealer's manuals and instruction manuals can be viewed on-line on our website (<http://si.shimano.com>).
- Please observe the appropriate rules and regulations of the country, state or region in which you conduct your business as a dealer.

For safety, be sure to read this dealer's manual thoroughly before use, and follow it for correct use.

The following instructions must be observed at all times in order to prevent personal injury and physical damage to equipment and surroundings.

The instructions are classified according to the degree of danger or damage which may occur if the product is used incorrectly.

 **DANGER**

Failure to follow the instructions will result in death or serious injury.

 **WARNING**

Failure to follow the instructions could result in death or serious injury.

 **CAUTION**

Failure to follow the instructions could cause personal injury or physical damage to equipment and surroundings.

TO ENSURE SAFETY

WARNING

- **When installing components, be sure to follow the instructions that are given in the instruction manuals.**

It is recommended to use genuine Shimano parts only. If parts such as bolts and nuts become loose or damaged, the bicycle may suddenly fall over, which may cause serious injury.

In addition, if adjustments are not carried out correctly, problems may occur, and the bicycle may suddenly fall over, which may cause serious injury.

-  Be sure to wear safety glasses or goggles to protect your eyes while performing maintenance tasks such as replacing parts.
- After reading the dealer's manual thoroughly, keep it in a safe place for later reference.

NOTE

Be sure to also inform users of the following:

- Be sure to keep turning the crank during the lever operation.
- If gear shifting operations do not feel smooth, wash the derailleur and lubricate all moving parts.
- Products are not guaranteed against natural wear and deterioration from normal use and aging.
- For maximum performance we highly recommend Shimano lubricants and maintenance products.

For Installation to the Bicycle, and Maintenance:

- Using a frame with internal cable routing is strongly discouraged as it has tendencies to impair the SIS shifting function due to its high cable resistance.
- Grease the inner cable and the inside of the outer casing before use to ensure that they slide properly. If the inner cable grease has been wiped off, it is recommended to apply grease SIS-SP41 (Y04180000). Also, make sure foreign objects, such as sand or mud, do not adhere to the inner cable.
- For smooth operation, use the specified outer casing (OT-SP41) and the bottom bracket cable guide (SM-SP17 / SP18).
- A special grease is used for the gear shifting cable. Do not use Premium grease or other types of grease, otherwise they may cause deterioration in gear shifting performance.
- Use an outer casing which still has some length to spare even when the handlebars are turned all the way to both sides. Furthermore, check that the shifting lever does not touch the bicycle frame when the handlebars are turned all the way.
- If gear shifting adjustments cannot be carried out, check that the rear fork ends are aligned. Also, check if the cable is lubricated and if the outer casing is not too long or short.

The actual product may differ from the illustration because this manual is intended mainly to explain the procedures for using the product.

INSTALLATION

■ Tools recommended

ROAD

Tool	Size
Allen key	4 mm
Screwdriver	#1,#2

MTB

Tool	Size
Allen key	3 mm, 4 mm, 5 mm
Screwdriver	#1,#2
Spanner	7 mm

■ Installation to the handlebar

Note:

Even tightening to the recommended tightening torque, over tightening may cause damage to the carbon material, and under tightening can cause lack of fixing strength for the components. When installing the components to carbon frame / handle bar surfaces, verify with the manufacturer of the carbon frame / parts for their recommendation on tightening torque.

- Install the shifting lever in a position where it will not obstruct brake operation and gear shifting operation.
- Do not use in a combination which causes brake operation to be obstructed.

ROAD

Use a handlebar grip with a maximum outer diameter of 36 mm.

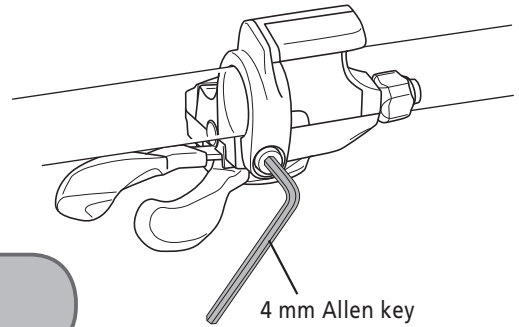

Tightening torque:
3.0 N·m {26 in. lbs.}

MTB

XTR / DEORE XT

Use a handlebar grip with a maximum outer diameter of 32 mm.

SAINT / SLX / DEORE LX / ZEE

Use a handlebar grip with a maximum outer diameter of 36 mm.

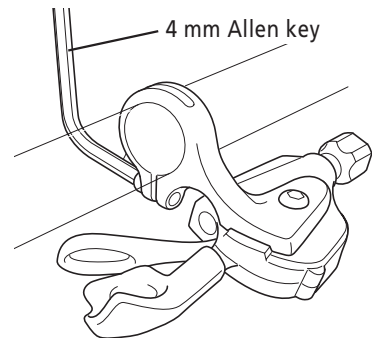

Tightening torque:
3.0 N·m {26 in. lbs.}

ALIVIO / ACERA / ALTUS

Use a handlebar grip with a maximum outer diameter of 36 mm.

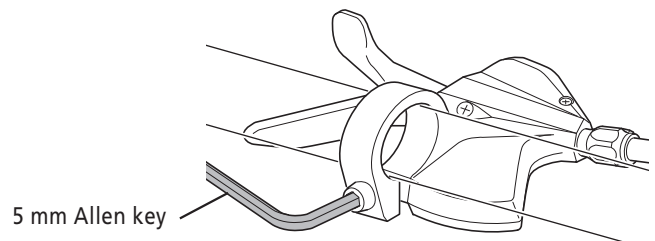

Tightening torque:
5.0 N·m {44 in. lbs.}



* ST-M3050: 6.0 - 8.0 N·m {53 - 69 in. lbs.}

■ In the case of the I-spec system

Note:

- For I-spec, combine the shifting lever (SL) and the brake lever (BL) and fix them onto the handle.
Note that the combining procedure differs depending on the product. The combining procedure is the same as Step 2 on the following page.
- Each bolt has a different specified torque.

Compatibility of shifting lever and brake lever

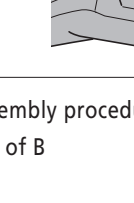
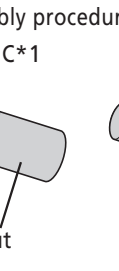
		Shifting Lever	
		New type	Conventional type
Brake lever	New type 	[Assembly procedure]: In the case of B 	
	Conventional type 	[Assembly procedure]: In the case of C* 1 	

* 1 Compatible grip diameter: ϕ 32 mm

List of models by type

	Model No. of the old type	Model No. of the new type
BL	BL-M985	Models other than those shown on the left
	BL-M988	
	BL-M820	
	BL-M785	
	BL-T785	
	BL-M675	
	BL-T675	
	BL-M640	
	BL-M596	
	BL-T780	
	BL-T670	
	BL-S700	
SL	SL-M980-A-I	
	SL-M820-I	
	SL-M780-I	
	SL-M670-I	
	SL-S700	

1. Use a 2 mm Allen key to open the clamp band of the brake lever as shown in the illustration.

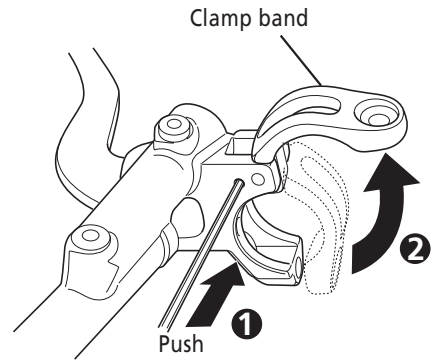

2. In the case of A

A-1

Insert the hook of the shifting lever bracket into the hole, and temporarily tighten the special nut and special bolt.

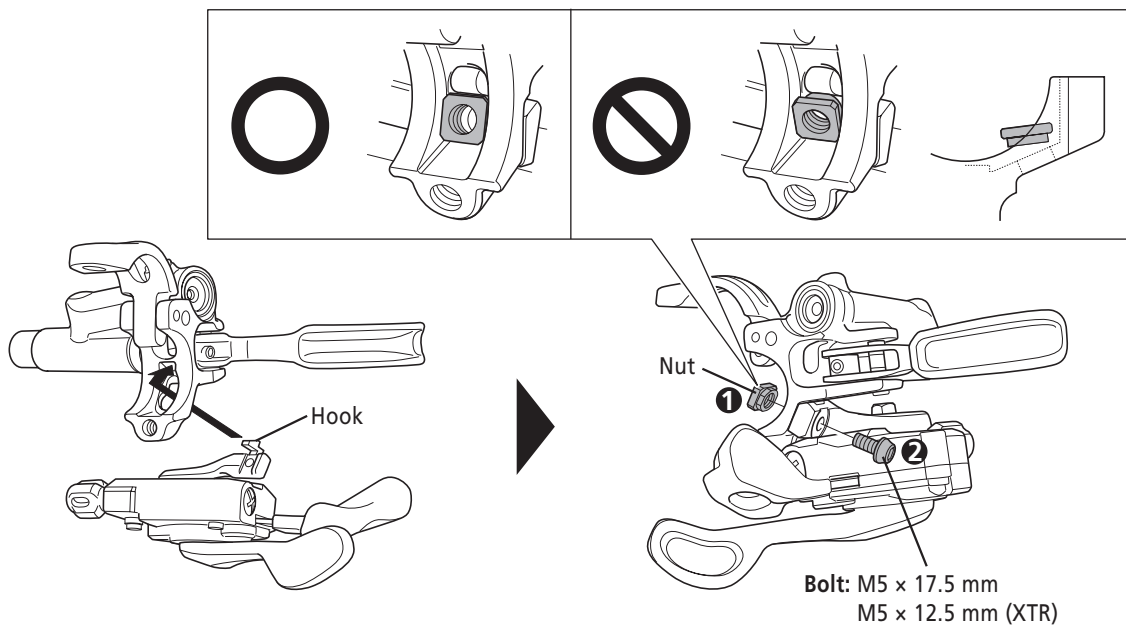

Note:

Do not install the nut upside-down.

If it is installed upside-down, it will not be possible to secure the brake lever to the handlebars, and damage may occur.

A-2

Use a 4 mm Allen key to secure the shifting lever to the brake lever.

4 mm Allen key

Tightening torque:
4.0 N·m {35 in. lbs.}

* XTR: 3.0 N·m {26 in. lbs.}

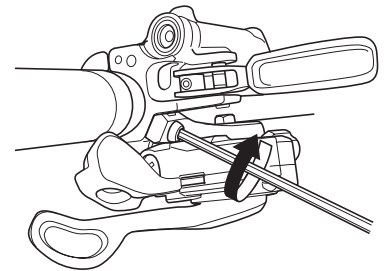

In the case of B, C

B-1

Insert **1** into the hole in the brake lever bracket, pass **2** through from the side into the nut hole of **1**, and tighten it using a 2 mm Allen key.

After that, attach the shifting lever with bolt **3**.

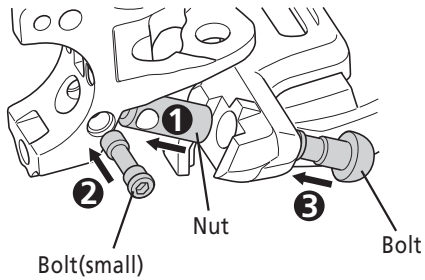

**Tightening torque:
1.0 N·m {9 in. lbs.}**

C-1

Attach it with the appropriate nut and bolt.

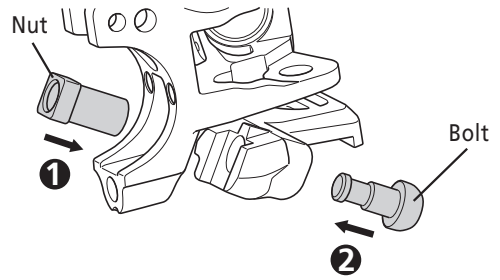

B-2 / C-2

Fix it to the brake lever with the dedicated nut and bolt using a 3 mm Allen key.

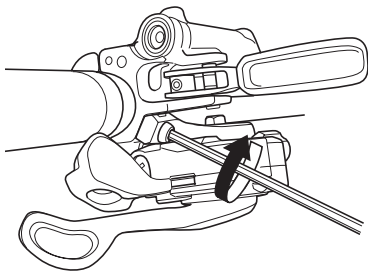

3 mm Allen key

**Tightening torque:
4.0 N·m {35 in. lbs.}**

* XTR: 3.0 N·m {26 in. lbs.}

3. Use a 4 mm Allen key to secure the clamp band of the brake lever.

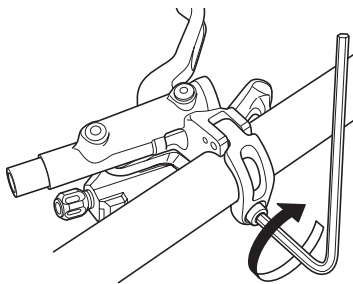

4 mm Allen key

**Brake lever tightening torque:
6.0 – 8.0 N·m {52 – 70 in. lbs.}**

* BL-M987: 4.0 - 6.0 N·m {35 - 52 in. lbs.}

Shifting lever position is adjustable by sliding to left or right.

* For SL-M610-I, shifting lever position is not adjustable.

7 mm Spanner or 4 mm Allen key

**Tightening torque:
2.5 N·m {22 in. lbs.}**

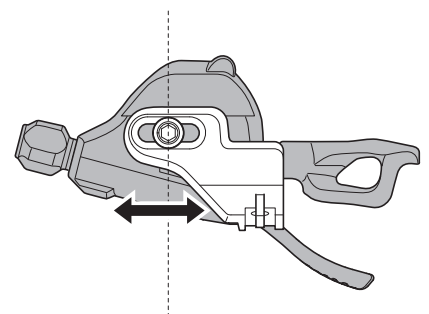

■ How to replace the normal spec system with the I-spec system

* The illustration shows the rear lever. Carry out the same procedure for the front lever.

XTR / SAINT / DEORE XT

* Components for replacement with I-spec are not available for SLX and DEORE.

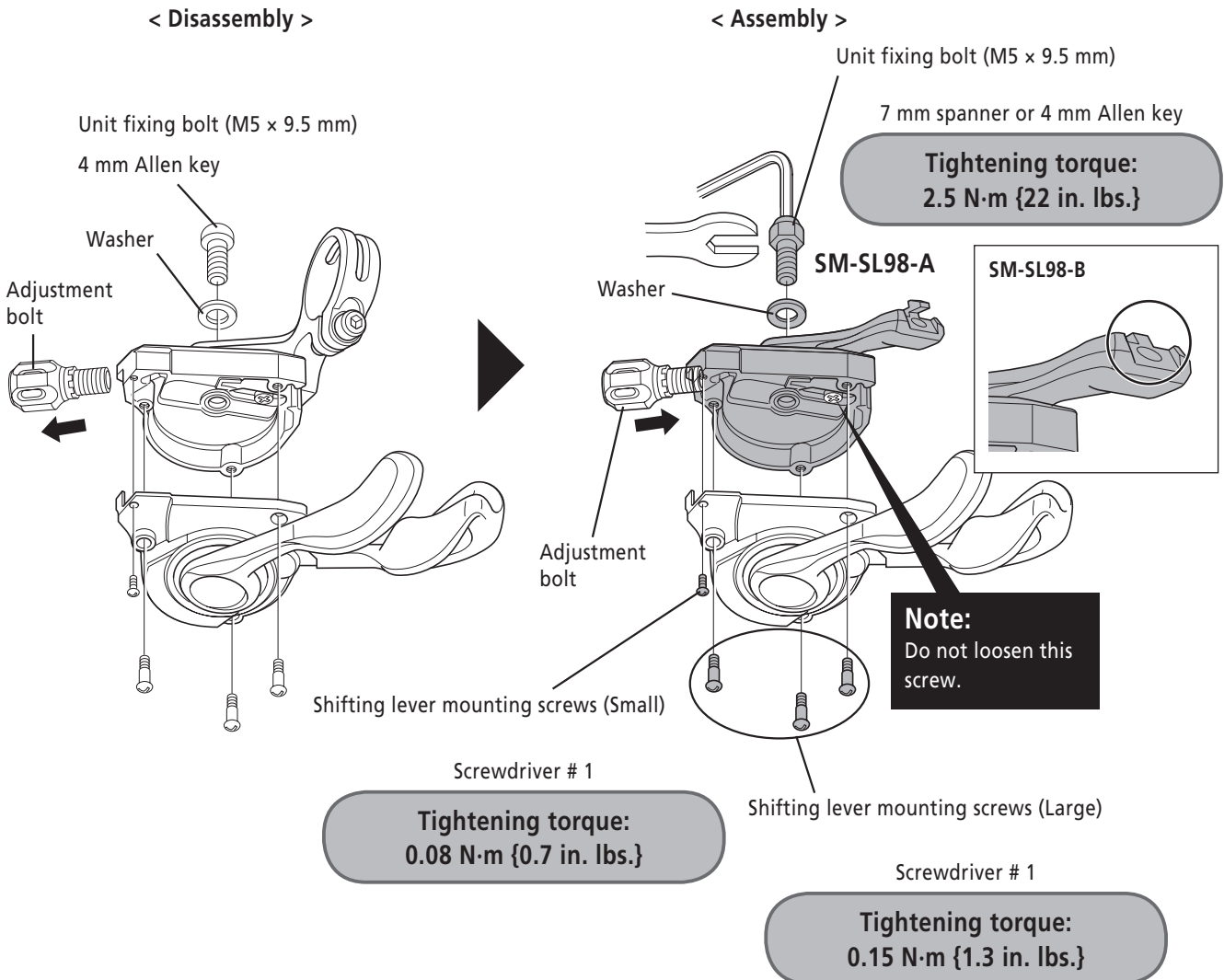

< Disassembly >

1. Loosen the cable fixing bolt (nut) of the front derailleur or rear derailleur, and then pull the inner cable out of the shifting lever unit in the same way as when installing the inner cable.
2. Remove the adjustment bolt.
3. First remove the unit fixing bolt.
4. Remove the four shifting lever mounting screws, and then remove the shifting lever unit as shown in the illustration.

< Assembly >

1. To assemble, align the shifting lever unit and the bracket band (SM-SL98-B, SM-SL98-A) and then secure the shifting lever mounting screws.
2. Place the washer onto the bolt, and tighten the unit fixing bolt.
3. Install the adjustment bolt.

MAINTENANCE

■ Replacing the inner cable

* Refer to SIS Adjustment in the Rear Derailleur section of General Operations for information on installation to the derailleur and necessary adjustments.

List of recommended inner cables

Category	Series	Outer casing	Material or surface treatment
MTB/ Trekking	XTR	OT-SP41	SIL-TEC
	SAINT	OT-SP41	Stainless
	DEORE XT	OT-SP41	Stainless
	DEORE LX	OT-SP41	Stainless
	SLX	OT-SP41	Stainless
	ZEE	OT-SP41	Stainless
	DEORE	OT-SP41	Stainless
	ALIVIO	OT-SP40	Stainless
	ACERA	OT-SP40	Steel
	ALTUS	OT-SP40	Steel

Category	Series	Outer casing	Material or surface treatment
ROAD	Tiagra (4700 series)	OT-SP41	OPTISLICK
	Tiagra	OT-SP41	Stainless
	SORA	OT-SP41	Stainless
	Claris	OT-SP41	Stainless
	Non-Series	OT-SP41	Stainless

MTB / Trekking

When there is a mode converter

< For Front >

2 x 10

1. Switch the mode converter to the 3x (triple mode) position, and then check the lowest position. Operate lever (B) two times or more to set the lever to the lowest position. Remove the wire end hooking cap, and install the cable.

< XTR / DEORE XT >

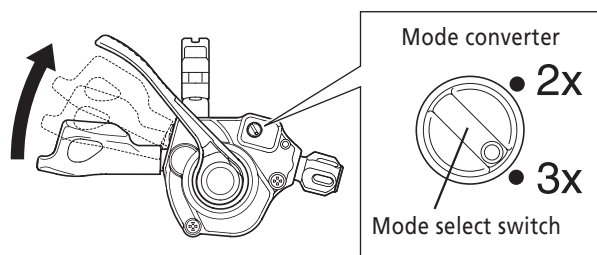

Note:

Do not force the mode select switch to turn. If you force it to turn, it will break.

< SLX / DEORE >

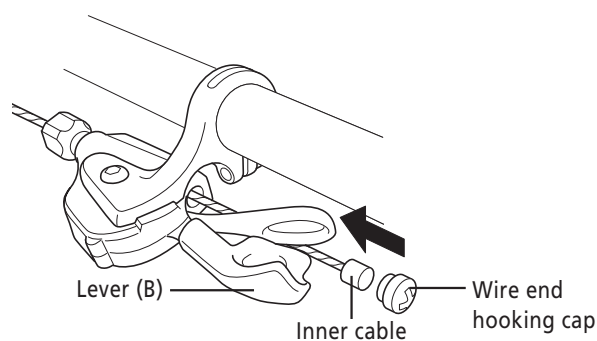
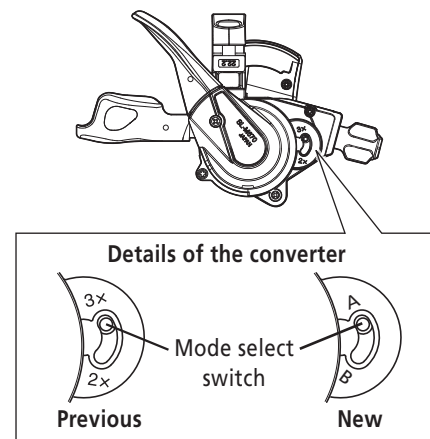

- Operate lever (A) once to set it to the middle position.
Switch the mode converter to the 2x (double mode) position.

* For FD-M677/FD-M617/FD-M618 there is no need to switch the mode converter.

< XTR / DEORE XT >

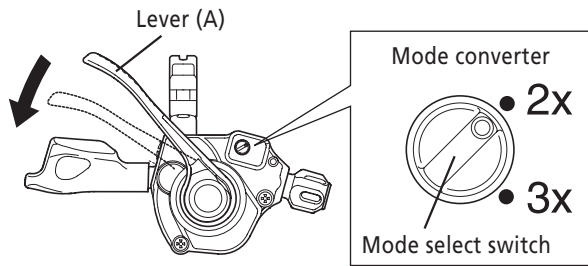

Note:

The mode converter cannot be switched while the lever is at the lowest position.

Be sure to operate lever (A) one or more times before switching.

Do not turn the mode converter by force, otherwise it may break.

< SLX / DEORE >

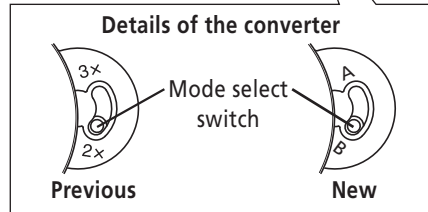
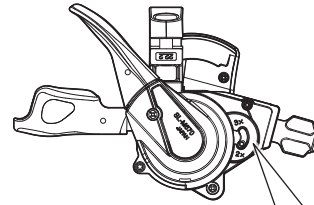

2 x 10s	Mode converter positions on the shift lever
FD-M677 FD-M617 FD-M618	
FD-M675 FD-M676 FD-M615 FD-M616	

- Install the wire end hooking cap by turning it as shown in the illustration until it stops. Do not turn it any further than this, otherwise it may damage the thread on the cover.

Wire end hooking cap

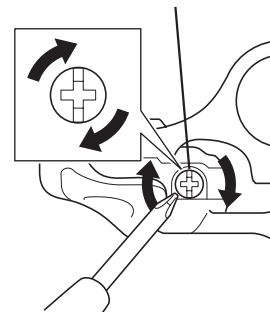

3 x 10

1. Switch the mode converter to the 3x (triple mode) position, and then check the lowest position. Operate lever (B) two times or more to set the lever to the lowest position. Remove the wire end hooking cap, and install the cable.

* SL-T780 / SL-T670 is not equipped with a mode converter.
Set the lever to the low position.

< XTR / DEORE XT >

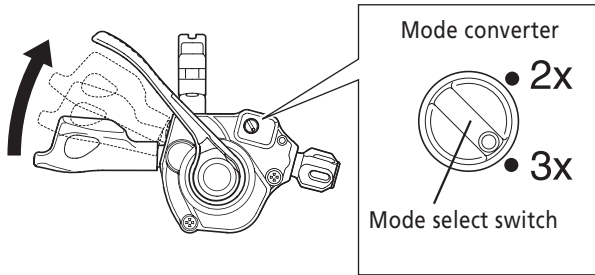

Note:

Do not force the mode select switch to turn.
If you force it to turn, it will break.

< SLX / DEORE >

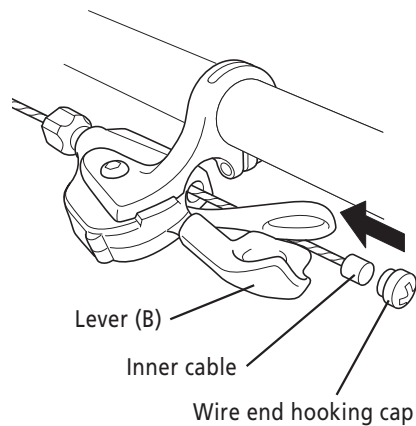
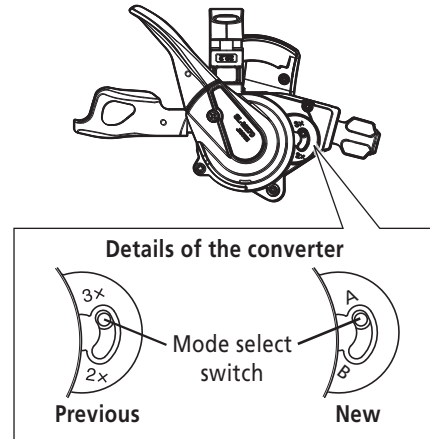

2. Install the wire end hooking cap by turning it as shown in the illustration until it stops. Do not turn it any further than this, otherwise it may damage the thread on the cover.

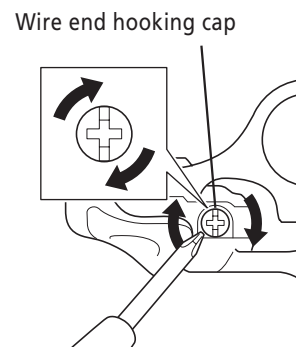

< For Rear >

1. Operate the lever (B) 9 times or more to set the lever to the highest position. Then remove the wire end hooking cap and connect the inner cable.

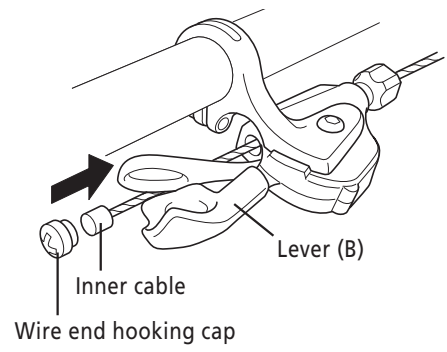

2. Install the wire end hooking cap by turning it as shown in the illustration until it stops. Do not turn it any further than this, otherwise it may damage the screw thread.

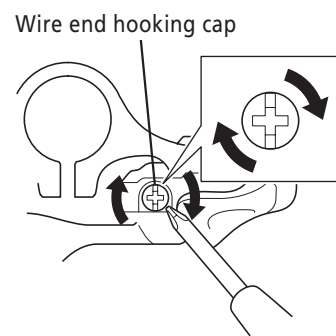

When there is no mode converter

1. Set lever (B) to the smallest gear / sprocket.
* The illustration shows the rear lever.

Specifications	Lever (B) operation count
2-speed	1 times or more
3-speed	2 times or more
7-speed	6 times or more
8-speed	7 times or more
9-speed	8 times or more
10-speed	9 times or more

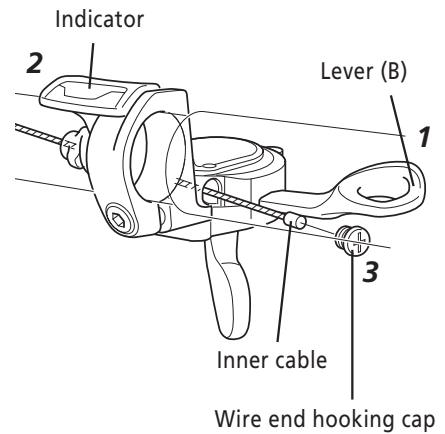

2. When there is an indicator.
Check the position on the indicator.

Front: right end

Rear: left end

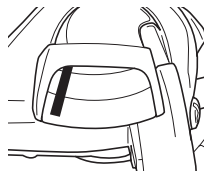
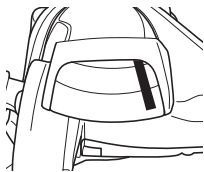

3. Remove the wire end hooking cap and install the cable.
4. Install the wire end hooking cap by turning it as shown in the illustration until it stops. Do not turn it any further than this, otherwise it may damage the screw thread.

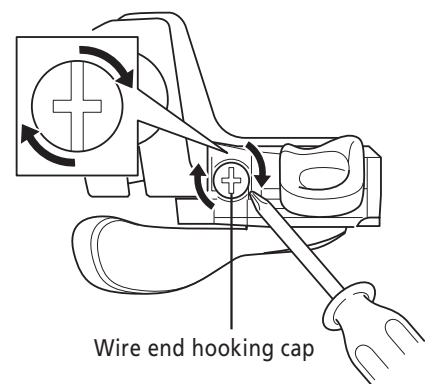

■ Replacement and reassembly of the indicator unit

* Carry out disassembly and reassembly only when removing or replacing the indicator unit.

MTB / Trekking

SLX / DEORE XT / DEORE LX

Note:

If the front lever is equipped with a mode converter, be sure to switch to triple mode before replacing the indicator unit. If replacement is performed in double mode, the indicator unit may be damaged. To use the unit in double mode after replacement, return the switch to the position 2x.

Replacement of the indicator unit

* The illustration shows the front lever.

< Disassembly >

Screwdriver # 1

Tightening torque:
0.15 N·m {1.3 in. lbs.}

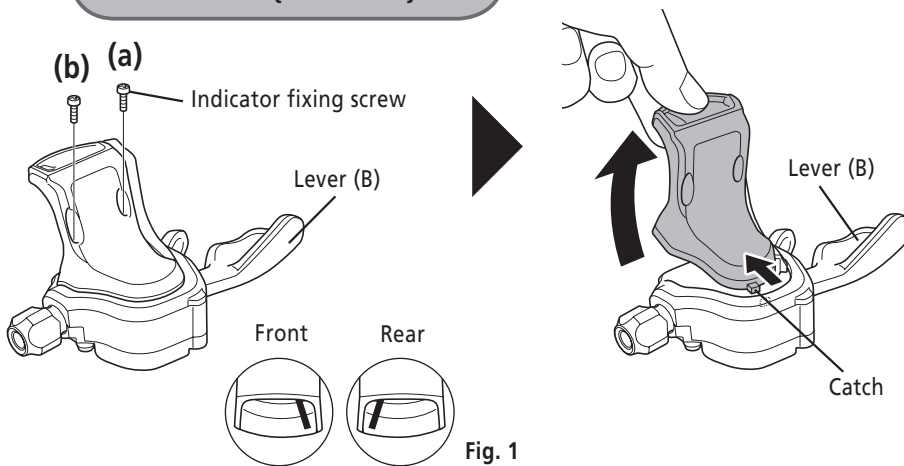

< Assembly >

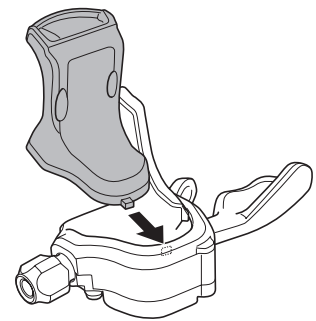

< Disassembly >

1. Operate lever (B) three or more times (nine or more times for the rear).
2. Remove the indicator fixing screws (a) and (b) which are securing the indicator unit, and then lift up the lens of the indicator unit to disengage the catch as shown in the illustration. Then remove the indicator unit.

* Do not mix up screws (a) and (b).
If they are mixed up, damage may result.

< Assembly >

1. Operate lever (B) three or more times (nine or more times for the rear).
2. Check the position on the indicator. (Fig. 1)
3. Install the indicator unit by first engaging the catch, and then secure it by tightening indicator fixing screws (a) and (b).
4. Check the operation. If the indicator unit does not operate correctly, reassemble while paying particular attention to steps 1 and 2.

Reassembly without the indicator (cover sold separately)

Once the indicator unit has been removed, install the cover (sold separately) by first attaching the catch, and secure it with the indicator fixing screw (a).

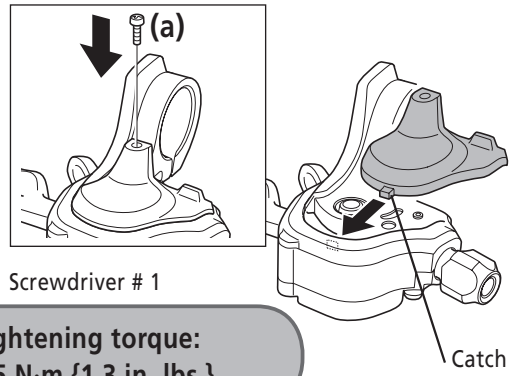

DEORE

* The illustration shows the rear lever.

< Disassembly / Assembly >

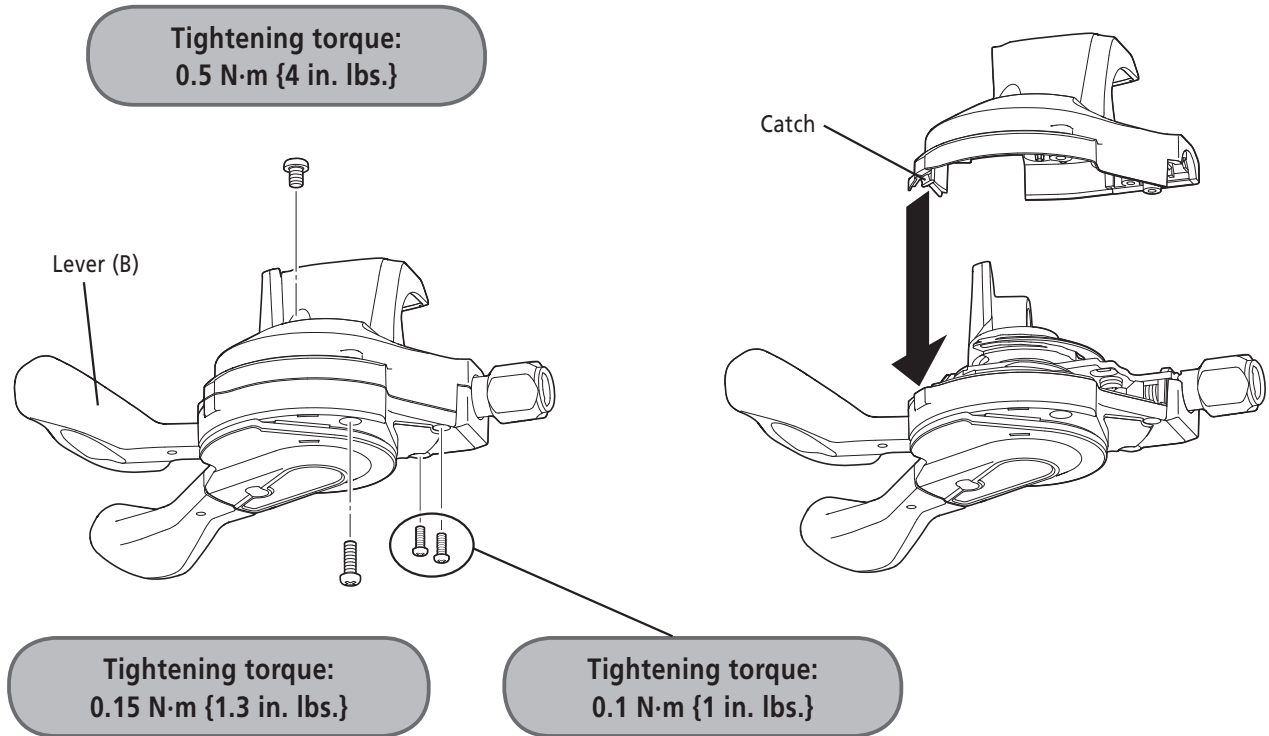

< Disassembly >

1. Remove the four indicator fixing screws.

< Assembly >

1. Set lever (B) to the smallest gear / sprocket.

Specifications	Lever (B) operation count
2-speed	1 times or more
3-speed	2 times or more
7-speed	6 times or more
8-speed	7 times or more
9-speed	8 times or more
10-speed	9 times or more

2. Check the position on the indicator.

Front: right end



Rear: left end

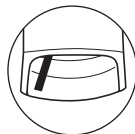

3. Install the indicator unit by first engaging the catch, and then secure it by tightening four indicator fixing screws.

4. Check the operation. If the indicator unit does not operate correctly, reassemble while paying particular attention to steps 1, 2 and 3.

ALIVIO / ACERA / ALTUS

* The illustration shows the rear lever.

< Disassembly / Assembly >

< ALIVIO / ACERA >

* Depending on the model, the indicator unit may not be replaceable.

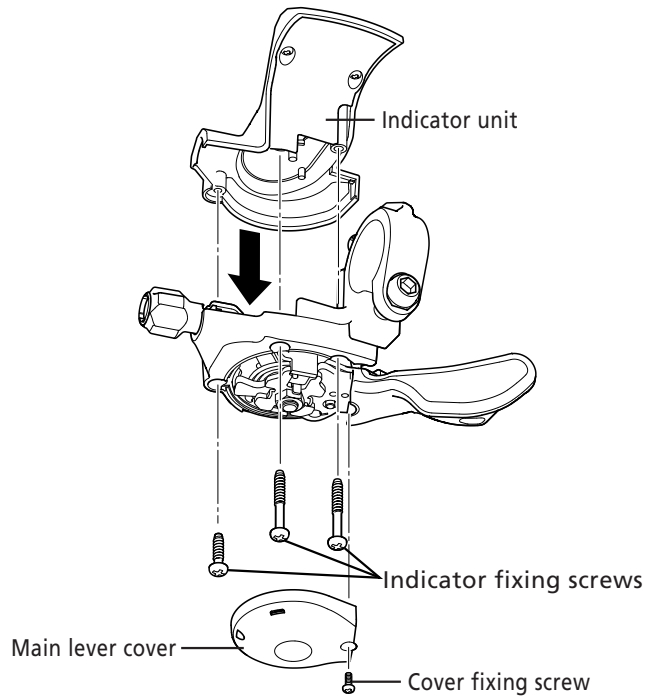

< Disassembly >

1. Remove the cover fixing screw and remove the main lever cover.
2. Remove the three indicator fixing screws.

< Assembly >

1. Set lever (B) to the smallest gear / sprocket.

Specifications	Lever (B) operation count
2-speed	1 times or more
3-speed	2 times or more
6-speed	5 times or more
7-speed	6 times or more
8-speed	7 times or more
9-speed	8 times or more

2. Check the position on the indicator.

Front: right end



Rear: left end

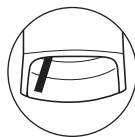

3. Install the indicator unit by first engaging the catch, and then secure it by tightening three indicator fixing screws.
Screwdriver # 2

Tightening torque	
Long	0.3 - 0.6 N·m {2.7 - 5.2 in. lbs.}
Short	0.2 - 0.4 N·m {1.8 - 3.5 in. lbs.}

4. Check the operation. If the indicator unit does not operate correctly, reassemble while paying particular attention to steps 1, 2 and 3.

< ALTUS >

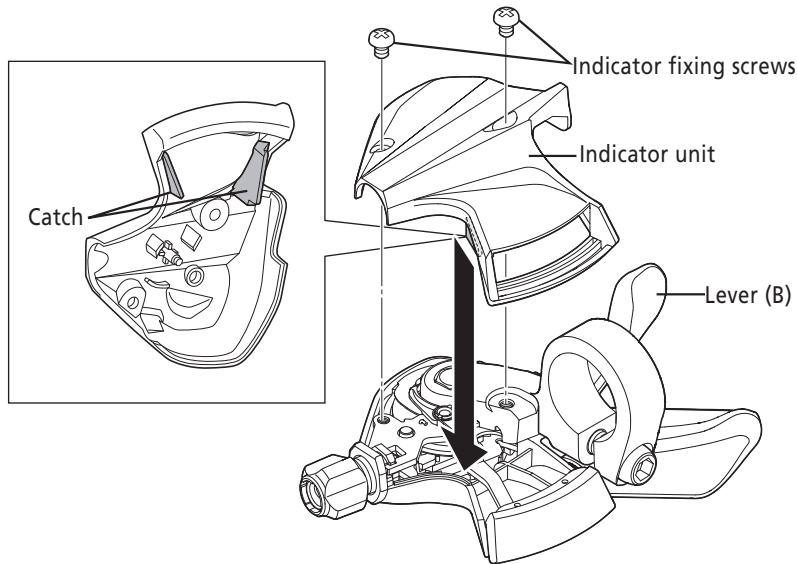

< Disassembly >

1. Remove the two indicator fixing screws.

< Assembly >

1. Set lever (B) to the smallest gear / sprocket.

Specifications	Lever (B) operation count
2-speed	1 times or more
3-speed	2 times or more
6-speed	5 times or more
7-speed	6 times or more
8-speed	7 times or more
9-speed	8 times or more

2. Check the position on the indicator.

Front: right end

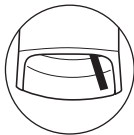

Rear: left end



3. Install the indicator unit by first engaging the catch, and then secure it by tightening two indicator fixing screws.
Screwdriver # 2

Tightening torque
0.2 - 0.5 N·m {1.8 - 4.3 in. lbs.}

4. Check the operation. If the indicator unit does not operate correctly, reassemble while paying particular attention to steps 1, 2 and 3.

Tiagra / SL-R460

* The illustration shows the rear lever.

< Disassembly >

- 1.** Remove the two indicator fixing screws.
- 2.** Turn the indicator unit clockwise as shown in the illustration, and then lift it to remove it.
(For the front: Turn it counterclockwise.)

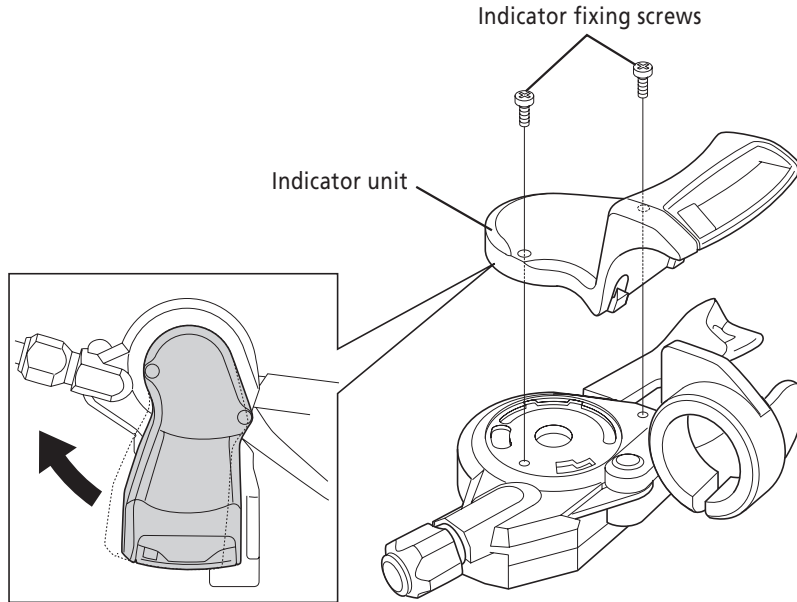

< Assembly >

- 1.** Set lever (B) to the smallest gear / sprocket.

Specifications	Lever (B) operation count
2-speed	1 times or more
3-speed	2 times or more
10-speed	9 times or more

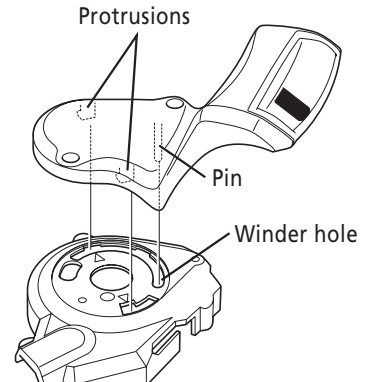

- 2.** Check the position on the indicator.

Front: right end



Rear: left end

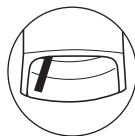

- 3.** Insert the pin at the bottom of the indicator into the winder hole unit and then insert the indicator unit so that the two protrusions are aligned with the Δ marks on the shifting lever unit.
- 4.** Turn the indicator unit counterclockwise as shown in the illustration to install it. (For the front: Turn it clockwise.)
- 5.** Secure the indicator unit by tightening the two indicator fixing screws.

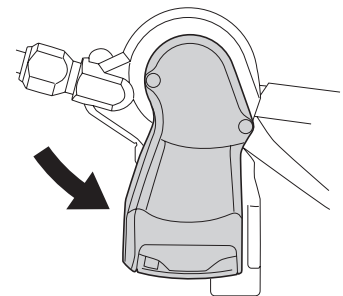

Tightening torque:
0.14 N·m {1.2 in. lbs.}

- 6.** Check the operation. If the indicator unit does not operate correctly, reassemble while paying particular attention to steps 1, 2 and 3.

SORA / Claris / SL-R350 / SL-R353

* The illustration shows the rear lever.

< Disassembly / Assembly >

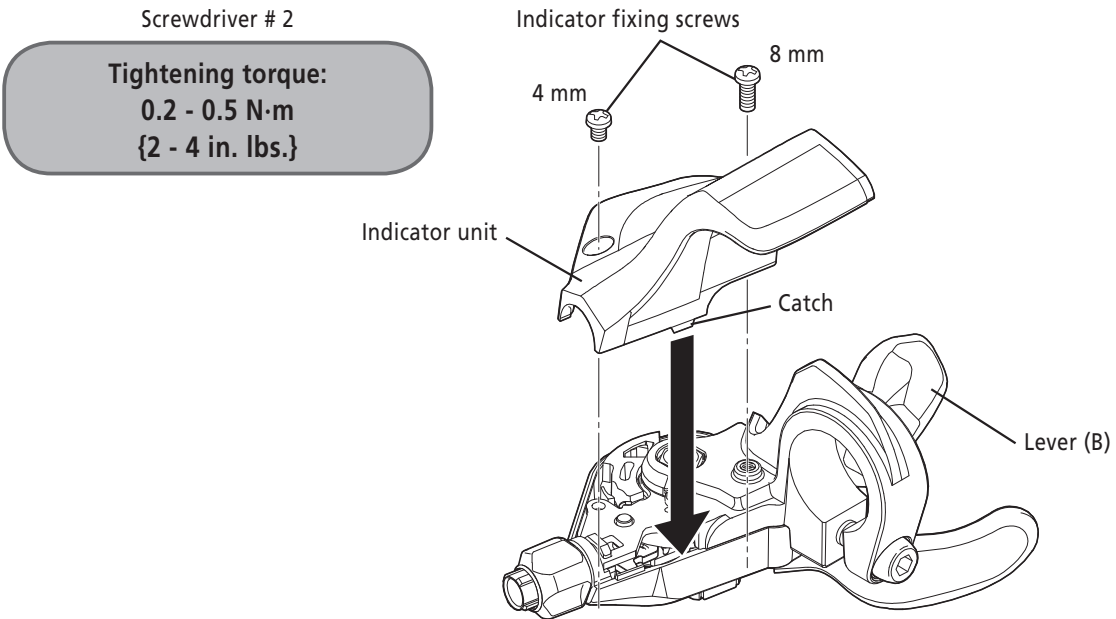

< Disassembly >

1. Remove the two indicator fixing screws.

< Assembly >

1. Set lever (B) to the smallest gear / sprocket.

Specifications	Lever (B) operation count
2-speed	1 times or more
3-speed	2 times or more
6-speed	5 times or more
7-speed	6 times or more
8-speed	7 times or more
9-speed	8 times or more

2. Check the position on the indicator.

Front: right end



Rear: left end

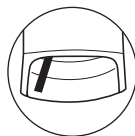

3. Install the indicator unit by first engaging the catch, and then secure it by tightening two indicator fixing screws.

4. Check the operation. If the indicator unit does not operate correctly, reassemble while paying particular attention to steps 1, 2 and 3.

■ Replacement of the shifting lever unit

Disassembly and reassembly should only be carried out when replacing the shifting lever unit.

MTB / Trekking

XTR / SAINT / DEORE XT

* The illustration shows the rear lever. Carry out the same procedure for the front lever.

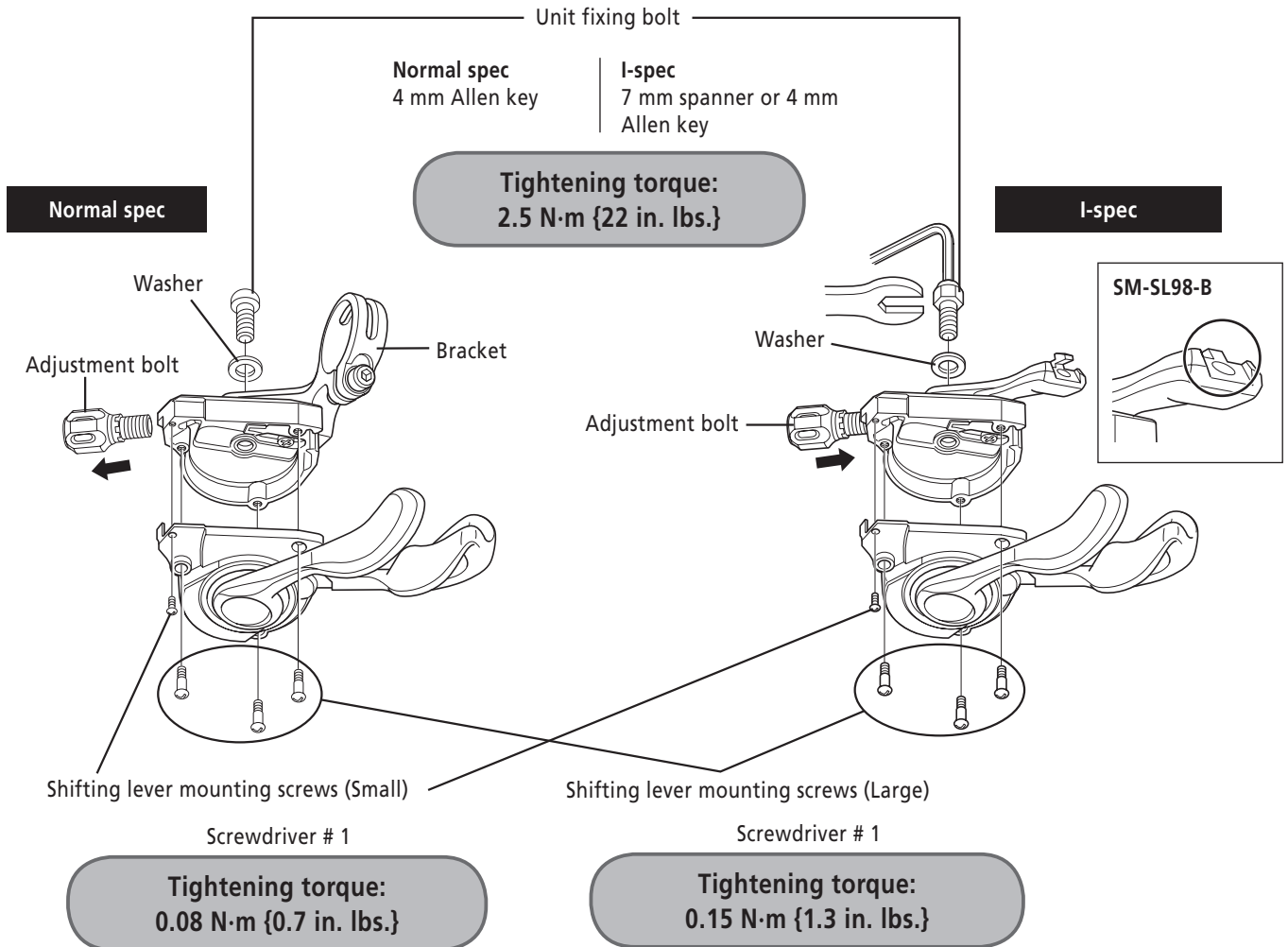

1. Loosen the cable fixing bolt (nut) of the front derailleur or rear derailleur, and then pull the inner cable out of the shifting lever unit in the same way as when installing the inner cable.
2. Remove the adjustment bolt.
3. First remove the unit fixing bolt.
4. Remove the four shifting lever mounting screws, and then remove the shifting lever unit as shown in the illustration.
5. To assemble, align the shifting lever unit and the bracket and then secure the shifting lever mounting screws.
6. Place the washer onto the bolt, and tighten the unit fixing bolt.
7. Install the adjustment bolt.

DEORE XT (Trekking)

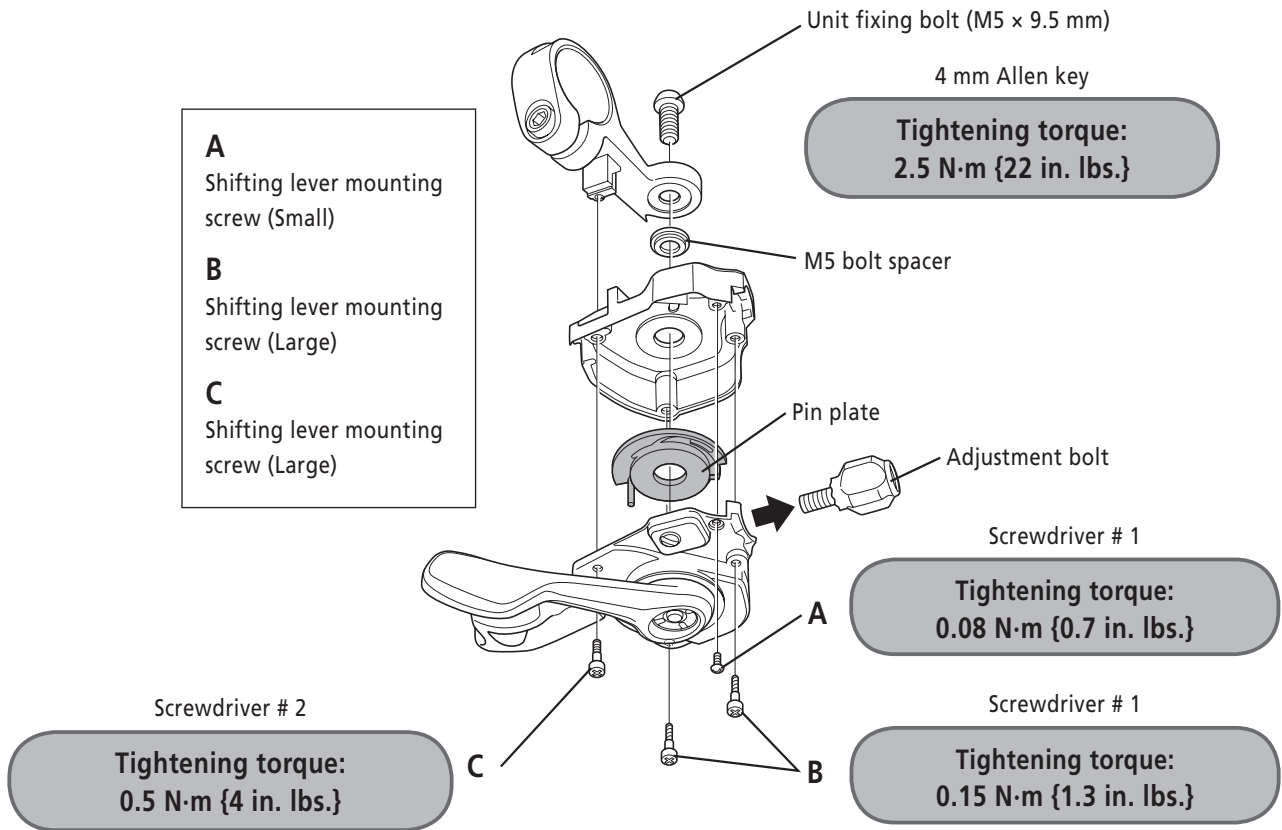

1. Loosen the cable fixing bolt (nut) of the front derailleur or rear derailleur, and then pull the inner cable out of the shifting lever unit in the same way as when installing the inner cable.
2. Remove the indicator unit by following the disassembly procedure given in Replacement of the indicator unit.
3. Remove the adjustment bolt.
4. Remove the unit fixing bolt.
5. Remove the four shifting lever unit mounting screws, and then remove the shifting lever unit as shown in the illustration.
*Be careful not to mix up screws A, B, and C.
6. Remove the pin plate from the shifting lever unit.

< Assembly >

1. Install the pin plate to the newly-assembled shifting lever unit.
*Insert the protrusions on the pin plate into the holes in the shifting lever unit as shown in the illustration.
2. Align the shifting lever unit and the bracket, and then secure with the four shifting lever unit mounting screws.
*Install the M5 bolt spacer before securing the screws.
3. Tighten the unit fixing bolt.
4. Install the adjustment bolt.
5. Install the indicator unit by following the assembly procedure given in "Replacement of the indicator unit".

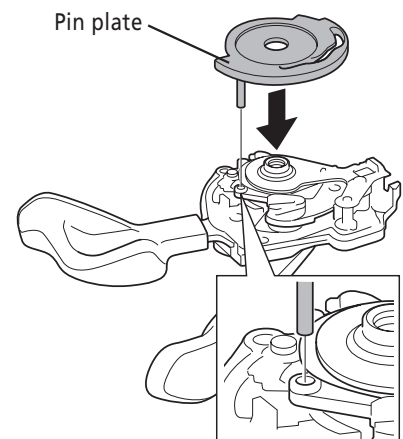

ROAD

Tiagra / SL-R460

Shifting lever unit mounting screw (Small)

Tightening torque:
0.08 N·m {0.7 in. lbs.}

Shifting lever unit mounting screw (Large)

Tightening torque:
0.14 N·m {1.2 in. lbs.}

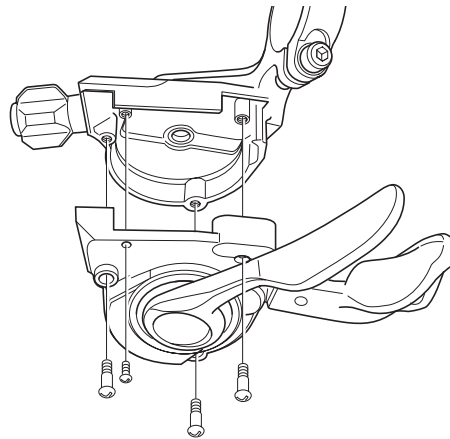

- 1.** Loosen the cable fixing bolt (nut) of the front derailleur or rear derailleur, and then pull the inner cable out of the shifting lever unit in the same way as when installing the inner cable.
- 2.** Remove the indicator unit by following the disassembly procedure given in Replacement and reassembly of the indicator unit.
- 3.** Remove the four shifting lever unit mounting screws, and then remove the shifting lever unit as shown in the illustration.
- 4.** Align the shifting lever unit and the bracket, and then secure with the four shifting lever unit mounting screws.
- 5.** Install the indicator unit by following the assembly procedure given in Replacement and reassembly of the indicator unit.

■ Replacement of the cover

MTB

ALIVIO / ACERA / ALTUS

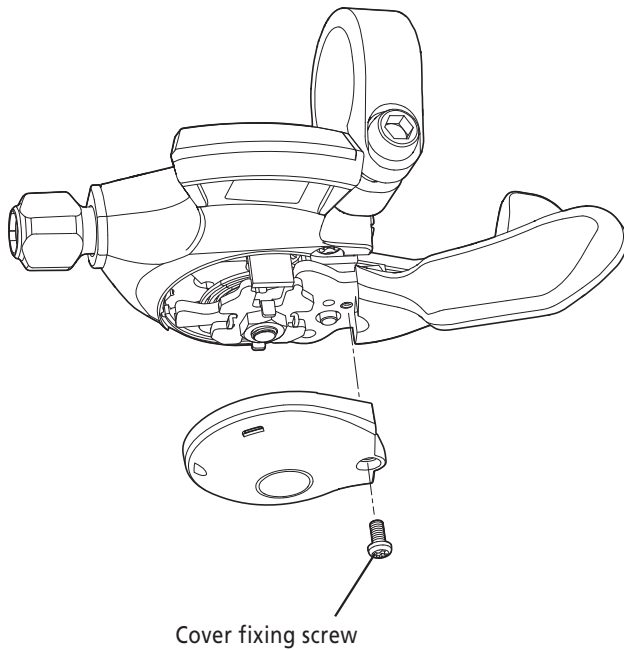

<ALIVIO/ ACERA>

Screwdriver # 1

Tightening torque:
0.1 - 0.3 N·m {0.9 - 2.6 in. lbs.}

<ALTUS>

Screwdriver # 1

Tightening torque:
0.2 - 0.5 N·m {1.8 - 4.3 in. lbs.}

ROAD

SORA / Claris / SL-R350 / SL-R353

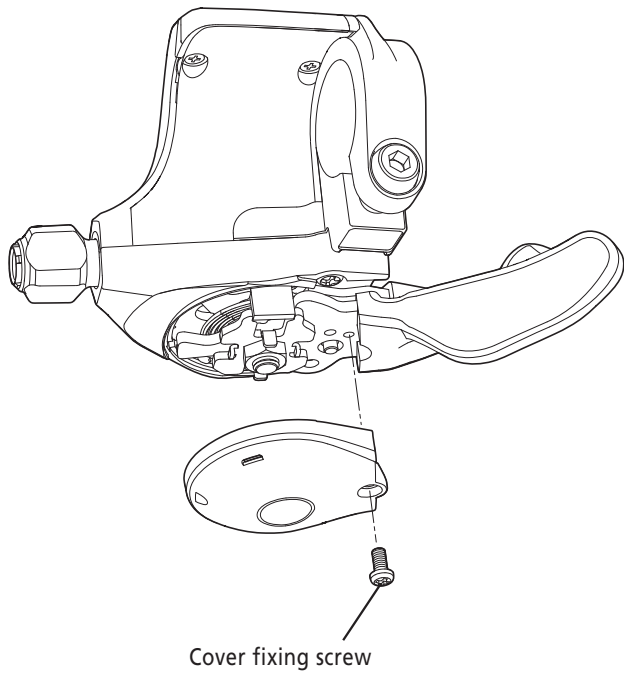

Screwdriver # 1

Tightening torque:
0.1 - 0.3 N·m {0.9 - 2.6 in. lbs.}

SHIMANO

SHIMANO AMERICAN CORPORATION

One Holland, Irvine, California 92618, U.S.A. Phone: +1-949-951-5003

SHIMANO EUROPE B.V.

Industrieweg 24, 8071 CT Nunspeet, The Netherlands Phone: +31-341-272222

SHIMANO INC.

3-77 Oimatsu-cho, Sakai-ku, Sakai-shi, Osaka 590-8577, Japan

Please note: specifications are subject to change for improvement without notice. (English)

© Mar. 2016 by Shimano Inc. HTR