



Thule XT Kit 3022

> Instructions

- VOLKSWAGEN Caddy**, 4/5-dr MPV, 04-15, 16-
- VOLKSWAGEN Caddy**, 4/5-dr Van, 04-15, 16-
- VOLKSWAGEN Caddy Maxi**, 4/5-dr MPV, 08-15, 16-
- VOLKSWAGEN Caddy Maxi**, 4/5-dr Van, 08-15, 16-

This kit is only for vehicles with fixpoint mounting.

The diagram is divided into several sections:

- Top Left:** A warning triangle icon and a Thule 'B' logo with the word 'THULE' and '> Instructions'.
- Top Middle:** A weight limit calculation: $xx\text{ kg} + xx\text{ lbs} + 6\text{ kg} / 13\text{ lbs} = \text{Max. } 100\text{ kg} / 220\text{ lbs}$. Below it, another calculation: $xx\text{ kg} + xx\text{ lbs} + 9\text{ kg} / 20\text{ lbs} = \text{Max. } 150\text{ kg} / 330\text{ lbs}$. The numbers 'xx kg' and 'xx lbs' are inside bag icons.
- Top Right:** A warning triangle icon and a diagram of a car roof with three downward arrows indicating load points.
- Bottom Left:** Three Thule instruction cards labeled 'A' with 'THULE' and 'Instructions'. The first is for '753 FootPack', the second for '959x Edge', and the third for '751 FootPack'. An arrow points from these cards to a silhouette of a person reading a manual.
- Bottom Right:** A warning triangle icon and a speedometer diagram. The speedometer has markings for 40 km/h (25 Mph), 80 km/h (50 Mph), and 130 km/h (80 Mph). A warning triangle is placed on the speedometer dial.

ISO 11154-E

183022

C.20150914
509-3022-03

Bring your life
thule.com

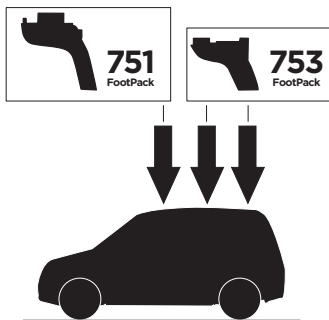
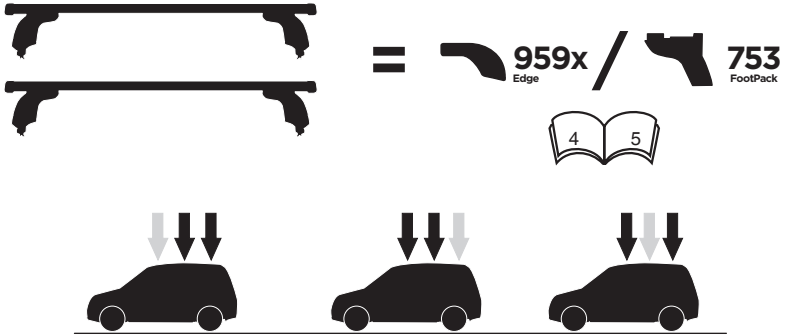



959x
Edge

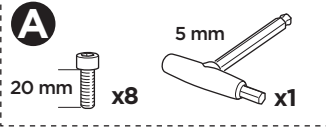

753
FootPack

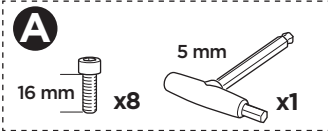

751
FootPack

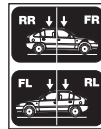
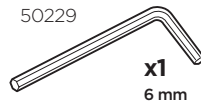
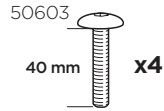
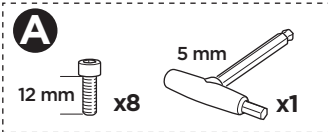

x1

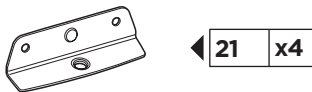

x1

1

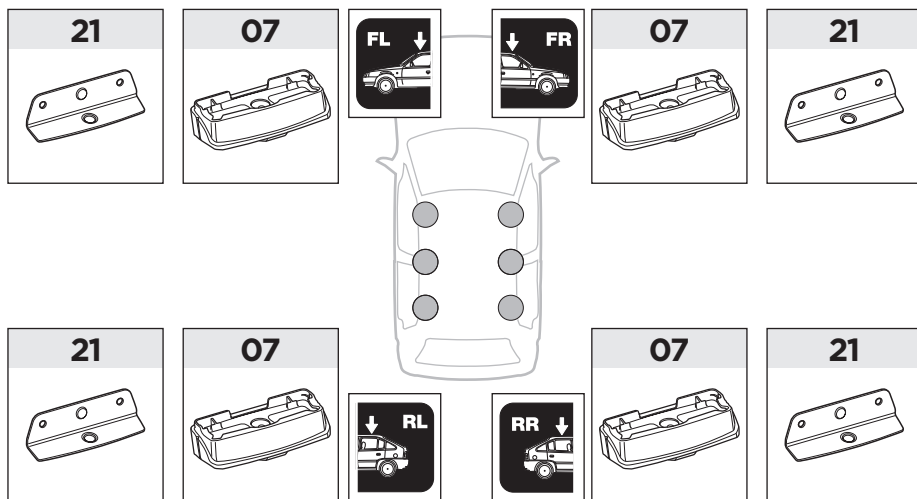
959x
Edge
 
753
FootPack

A

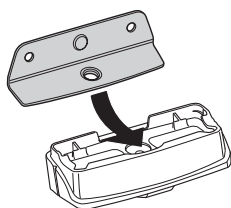

B

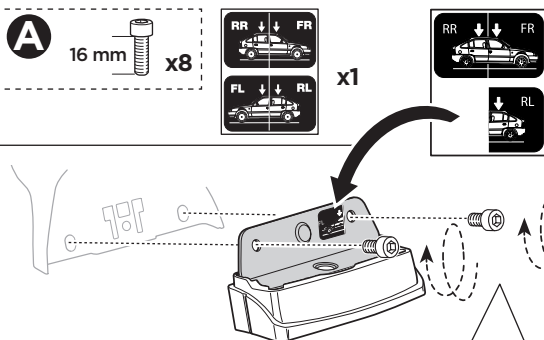

EN Only a few turns
DE Nur wenige Umdrehungen
FR Quelques tours uniquement
NL Slechts enkele slagen
IT Solo qualche giro
ES Sólo algunas vueltas
PT Apenas algumas voltas
SV Endast några varv
DK Kun nogle få omgange
NO Bare noen få omdreininger
FI Vain muutama kierros

ET Ainult mõni pööre
LV Tikai dažī apgriezieni
LT Tik keli pasukimai
PL Wystarczy kilka obrotów
RU Только несколько оборотов
UK Лише декілька обертів
BG Само няколко завъртания
CS Pouze několik otáček
SK Len niekoľko otáčok
SL Le nekaj obratov
HR/BiH Samo nekoliko okreta

RO Doar câteva rotiri
HU Csak néhány fordítás
EL Μόνο λίγες περιστροφές
TR Yalnızca birkaç tur

بعض دورات فقط **AR**
 רק מספר סיבובים **HE**

ZH 仅几圈
JA 2～3回転のみ
KO 몇 번만 돌리면 됨
TH เพียงสองสามรอบ

2**959x**
Edge**753**
FootPack**A**

5 mm

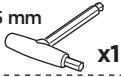

x1

6 mm

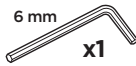

x1

40 mm



x4

x4

**A****A**

5 mm

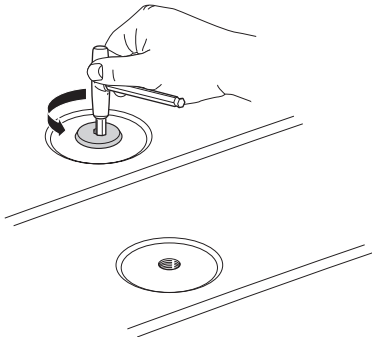
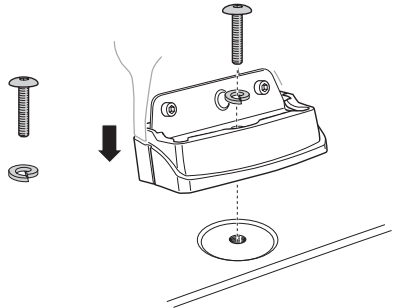

x1

**B****C**

6 mm

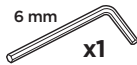

x1

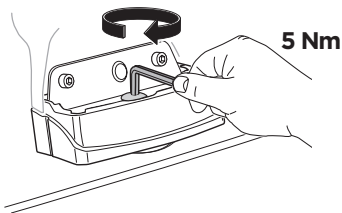

5 Nm

D**A**

5 mm

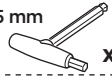

x1

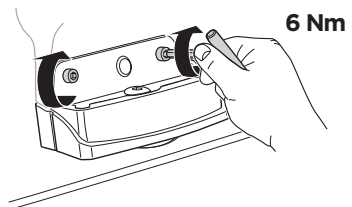

6 Nm

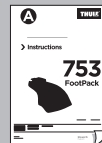
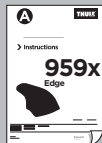

1

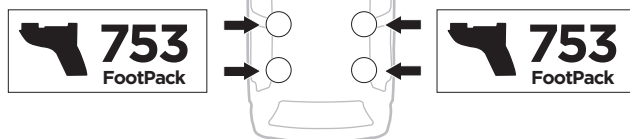
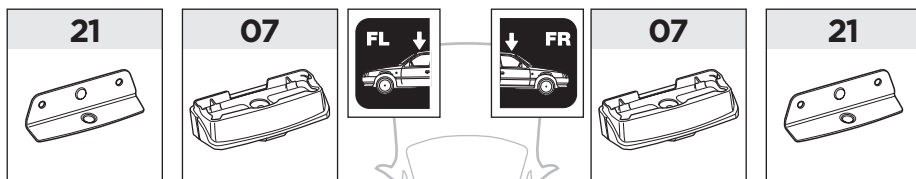

A

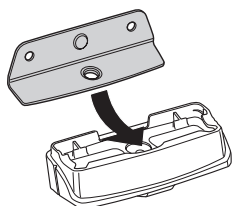

B

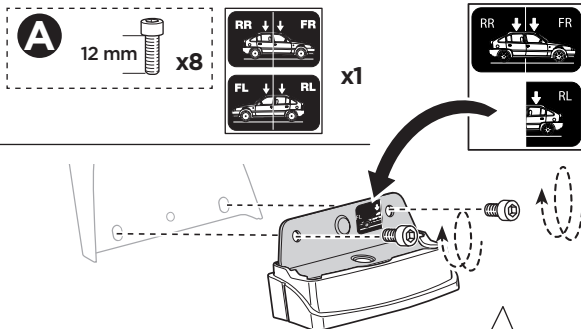

EN Only a few turns
DE Nur wenige Umdrehungen
FR Quelques tours uniquement
NL Slechts enkele slagen
IT Solo qualche giro
ES Sólo algunas vueltas
PT Apenas algumas voltas
SV Endast några varv
DK Kun nogle få omgange
NO Bare noen få omdreinger
FI Vain muutama kierros

ET Ainult mõni pööre
LV Tikai dažī apgriezieni
LT Tik keli pasukimai
PL Wystarczy kilka obrotów
RU Только несколько оборотов
UK Лише декілька обертів
BG Само няколко завъртания
CS Pouze několik otáček
SK Len niekoľko otáčok
SL Le nekaj obratov
HR/BIH Samo nekoliko okreta

RO Doar câteva rotiri
HU Csak néhány fordítás
EL Μόνο λίγες περιστροφές
TR Yalnızca birkaç tur

AR بعض دورات فقط
HE רק מספר סיבובים
ZH 仅几圈
JA 2 ~ 3 回転のみ
KO 몇 번만 돌리면 됨
TH เพียงสองสามรอบ

2

751 FootPack

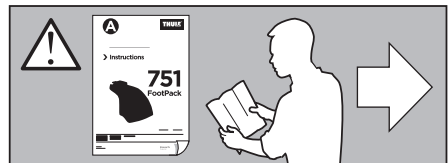
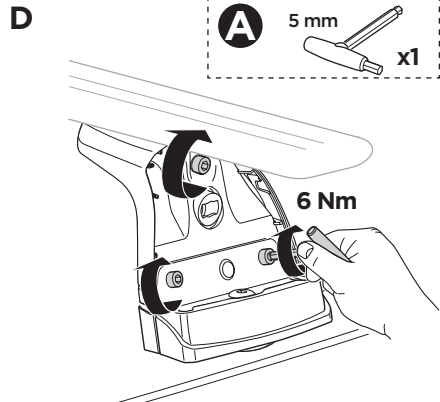
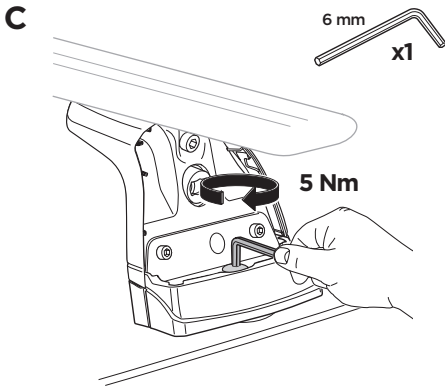
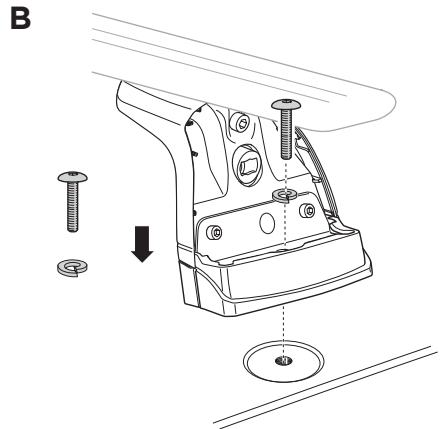
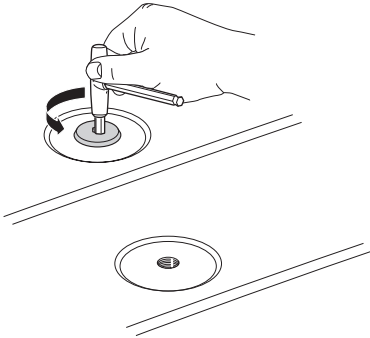
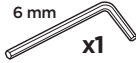



Thule Sweden AB, Box 69, 330 33 Hillerstorp, SWEDEN
Thule Inc., 42 Silvermine Road, Seymour, Connecticut 06483, USA



info@thule.com
Phone: 800-238-2388



www.thule.com