

PRODUCT INFO

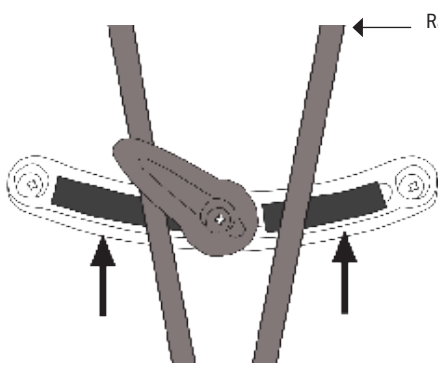

ABRASION PROTECTION FOR RACKS

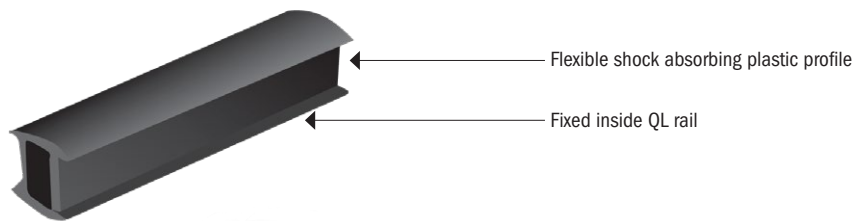

Mounting in semi ellipse of Quick-Lock1 system

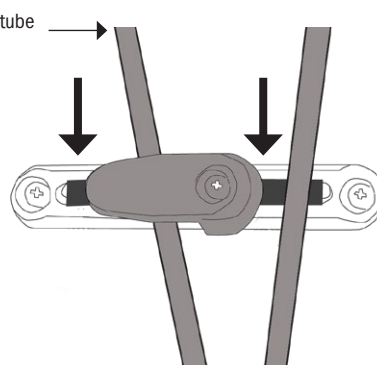

Mounting in Quick-Lock1 system

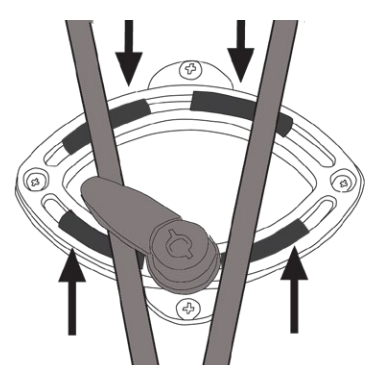

Mounting in Quick-Lock2 system

Article code	Weight g/oz.
E184	10/0.4

SPECIFICATIONS:

- + Abrasion protection for integration in lower mounting rails of bike panniers with Quick-Lock1- or Quick-Lock2 system
- + Prevents abrasion and reduces damage to rack tubes
- + Flexible and shock absorbing TPU plastic fabric
- + Can be shortened to required length by using scissors

Contents: Abrasion protection is supplied as set with 4 pieces